



Robezu 46, LV-1004 Riga, Latvia
Phone: +371-7-065100
Fax: +371-7-065102
In St. Petersburg, Russia:
Fax: +7-812-325-5856, Att. D. Korneev
E-mail: korneev@exch.nnz.spb.su

Operating Manual
Model No. PNS-10
High Power Pulsed Noise Source Assembly
94 +/-2.5 GHz



1st U.S. Edition, 99.02.04

Overview

ELVA-1's High Power Pulsed Noise Source is an excellent source of incoherent radiation. This device employs specially-designed silicon IMPATT diodes, operating in pulse mode, and delivers real incoherent radiation within a 5 GHz bandwidth at an output power level of one Watt (1 W). Low DC power requirements eliminate the need for complex, high-voltage supplies. A pulsed current source and triggering circuit are included in the design. A control switch allows the user to select either internal or external triggering. An internal, digitally-controlled generator provides trigger repetition rates between 10 Hz and 100 kHz.

Specifications

N	Descriptions	Measured value	Comments
1	Minimum Output Power, W	1	
2	Pulse Duration, ns	100	Fixed by internal circuitry, and independent of triggering pulses.
3	Repetition Rate, Hz	10-100k	Determined by External Triggering or by Internal Programmable Triggering Source.
4	Minimum Operating Frequency Band, GHz	91.5-96.5	
5	ENR Flatness, dB	+/-1.5	ENR was measured by receiver with 0.3 GHz bandwidth. Error bars are +/- 0.5 dB.
6	Output Power Stability, dB/°C	0.02	
7	External Triggering Input	TTL compatible	
8	Triggering Output	TTL compatible	

Construction

A block diagram of the Noise Source is shown below:

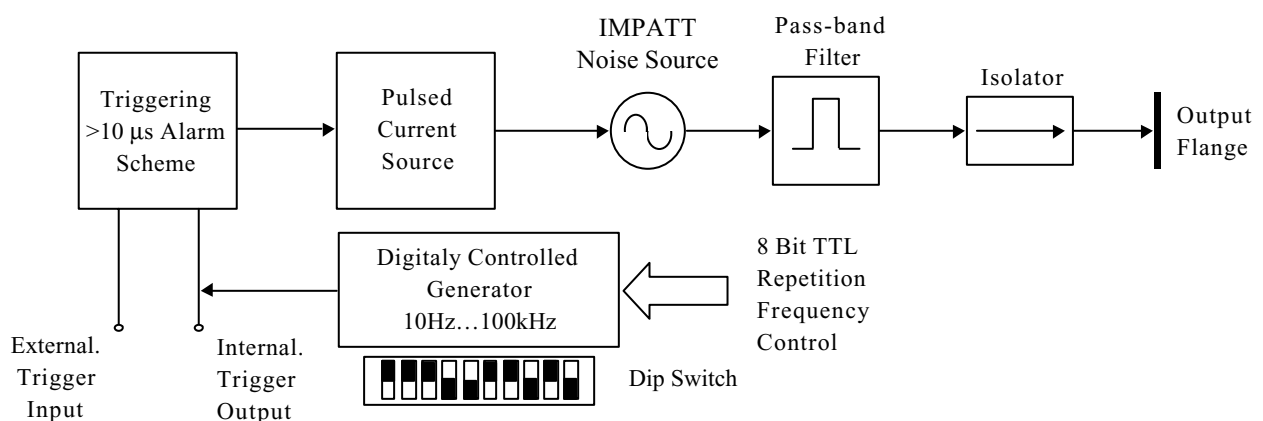

The Noise Source is comprised of the following elements:

1. Cavity with IMPATT diode noise source to generate noise power;
2. Bandpass filter to select the operating frequency range;
3. Isolator to protect the source from the load's reflected power;
4. Pulsed Current Source to produce current pulses of approximately 20A, with fixed amplitude and slope.
5. Digitally-controlled Generator to provide a pulse repetition rate in the range of 10 Hz to 100 kHz.

A special blanking circuit is provided to prevent the application of more than one triggering pulse to the diode within a 10 µsec period. The built-in, digitally-controlled triggering generator can provide any pulse repetition rate in 256 steps between 10 Hz and 100 kHz.

The desired frequency can be selected by setting the Dip Switches as required, or by instructions from an 8-bit TTL bus.

The Pulsed Current Source provides biasing current pulses of approximately 20A, with fixed amplitude and slope, to the IMPATT diode. The positive slope of the biasing current compensates for changes in the diode's parameters during a pulse, to produce a flat ENR.

Triggering

The Noise Source may be triggered either internally or externally. The triggering source (internal or external) is selected by the position of Switch 10 of the Dip Switch located in the outside cylinder wall of the Noise Source (see cover illustration). If SW10 is ON, triggering is provided by the internal programmable generator. In this mode, a triggering pulse repetition rate can be set at any one of 256 steps between 10 Hz and 100 kHz by either Dip Switch positioning or instructions from an 8-bit parallel TTL bus. SW9 provides selection between Local (dip switch) and Remote (8-bit TTL bus) repetition rate control modes. If SW9 is ON, the Local control mode is selected. An approximation of the internal triggering repetition rate can be calculated using the following formula: $100,000 - 392.1176 * N$ Hz, where N is the code selected on the Dip Switch or by the TTL bus. The exact frequency for each selection code is listed in the enclosed Excel file, titled: *Triggering Frequency Table.xls*. The external triggering input port is TTL compatible.

Controls

Disposition of connectors is shown on drawings below:

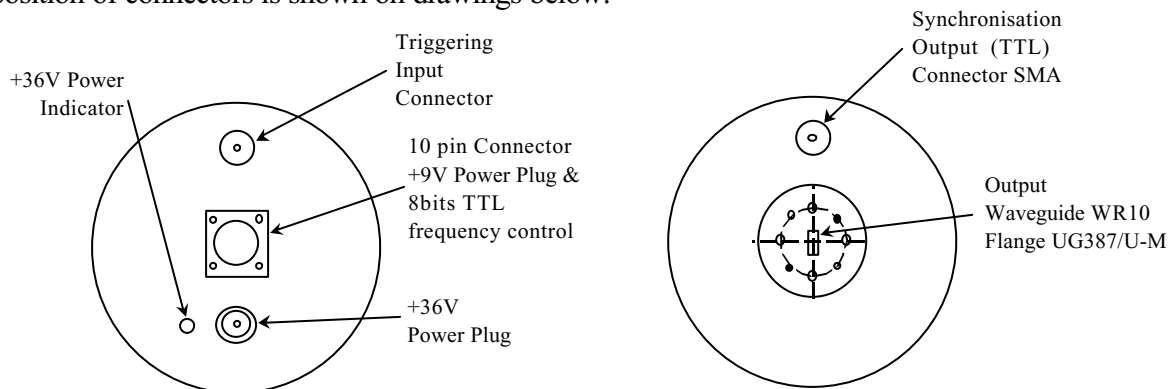

Dip Switch Settings:

Dip No.	SW1	SW2	SW3	SW4	SW5	SW6	SW7	SW8	SW9	SW10
Description	D0	D1	D2	D3	D4	D5	D6	D7	Local/ Remote	Int./Ext.
ON	0	0	0	0	0	0	0	0	Local	Internal
OFF	1	1	1	1	1	1	1	1	Remote	External

The location of the Dip Switch is shown in the cover illustration to this manual.

A 10-pin connector facilitates the application of the 8-bit code for repetition rate control and the +9VDC power for the digital circuitry. The pin-out configuration for this connector is illustrated below:

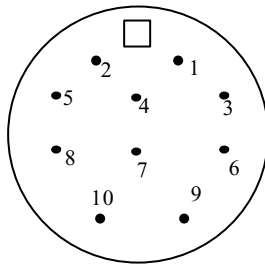

Pin Assignments for 10-pin Connector

Pin No.	P1	P2	P3	P4	P5	P6	P7	P8	P9	P10
Description	D0	D1	D2	D3	D4	D5	D6	D7	+9VDC	Ground
High level	0	0	0	0	0	0	0	0	-	-
Low level	1	1	1	1	1	1	1	1	-	-

A mating jack for the 10-pin plug is supplied with the hardware.

The +36 VDC Power jack was selected to be incompatible with a standard SMA jack, to prevent accidental application of 36 V to the Triggering Input SMA connector. A mating cable-mount plug for the non-standard +36 VDC jack is supplied with the hardware.

A Synchronized Output TTL signal is provided to trigger external devices.

Slope of the biasing current allows to compensate the change of the diode parameters during the pulse and so to provide flatness of ENR during the pulse.



Operating Instructions

WARNING! Do not switch *Internal/External* and *Local/Remote* switches (SW9 and SW10) while +36 VDC is applied. Always turn off +36 VDC before changing operating modes.

Connect all cables, and apply operating voltages in the following order:

1. +9 VDC (± 0.3 VDC).
2. Trigger pulses ON.
3. +36 VDC (± 0.2 VDC).

The shutdown sequence should be the reverse of the above.

Before applying external triggering pulses, make sure that the pulse rate is less than 100 kHz.

Allow three (3) minutes warm-up time before taking measurements.

The repetition rate may be changed with the Dip Switch or the 8-bit bus control while the unit is under power. A photo of a typical noise pulse, measured on the output of a detector with a 50-Ohm load is shown below:

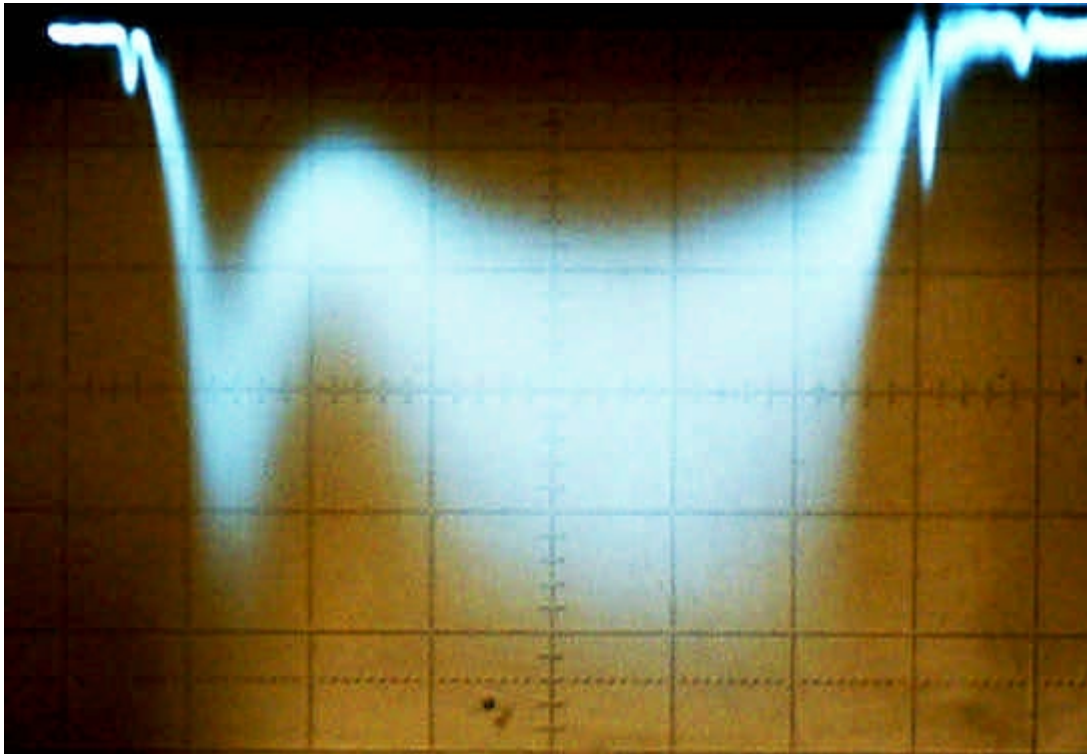

Integration time of the detector is about 3 ns. Scale is 20 ns per division.

