



46 Robezu str. LV-1004 Riga, Latvia

Fax: +371-7-065102

Mm-wave Division in St. Petersburg, Russia

Fax: +7-812- 326-10-60

Tel: +7-812-326-59-24

E-mail: ivanovph@nnz.ru

Millimetre Wave Generator G4-143g



Operation manual
(4rd edition, 10.05.2001)

Millimeter Wave Generator G4-143g.

User Manual.

Contains.

1. GENERAL REMARKS	3
2. EXPLOITATION	3
3. PARAMETERS	3
4. RELIABILITY	4
5. CONSTRUCTIVE PARAMETERS	4
6. PRINCIPLE OF OPERATION	4
7. OPERATION MANUAL	7
8. HOW TO TURN ON THE GENERATOR	7
9. PURSUANCE OF MEASUREMENTS	8
10. GPIB INTERFACE	14
Supplements	14
1. Front panel of the Generator.....	16
2. Front panel of the Generator.....	17
3. Disposition of the units in the Generator	18
4. Block diagram of the control unit	19
5. The structure of the calibration files.	20
6. The diagram of the Control Voltage and strobos.....	21
7. Output power versus frequency	22
8. Frequency versus Control voltage, Frequency versus High voltage monitor	23
9. Electrical Scheme of BWO Tube	24

1. GENERAL REMARKS

- 1.1. Microwave generator G4-143g, hereinafter called Generator, is intended to be used as a signal source in the millimetre range of wavelengths for tuning and adjustment of the radio-electronic device.
- 1.2. The Generator may be used in laboratory conditions.

2. EXPLOITATION

Conditions:

operations temperature:	5°-40° C°
relative air humidity :	up to 95% at the temperature 30° C°
primary power:	AC(220±10)V/(50±0.5)Hz
atmospheric pressure:	84-112 kPa.

Some abbreviation, used hereinafter:

- BWO - Back Wave Oscillator
- VSWR - Voltage Standing Wave Ratio
- CW - Continuous Wave
- OA - Operating Amplifier
- LCD - Liquid Crystal Display

3. PARAMETERS

- 3.1. Frequency range is 110-170 GHz. Device has a reserve more than 1% at the edges of the range.
- 3.2 Full band sweep time: less than 200 microseconds with external frequency control, 10 milliseconds with internal frequency control.
- 3.3. Admissible variation of the frequency of unmodulated oscillation, if primary power voltage changes up to ±10% for AC 50Hz, is no more than ±0.05%.
- 3.4. Relative variation of frequency of the output signal is no more than 10^{-4} , if the load VSWR changes from 1.1 to 1.3 at the output power 1mW. Output power should be installed using an external attenuator.
- 3.5. Limit of instability of the frequency of unmodulated oscillations at the unchanged primary power voltage during any 15 min of work is 0.01% (the warm-up time after adjustment from one frequency to another must be no less than 5 min).
- 3.6. 50 Hz deviation of the frequency of the CW output signal is no more than 0.002% in the mode with the frequency control by means of an external voltage.
- 3.7. Guaranteed power level of unmodulated oscillations is no less than 50 mW at the load VSWR no larger than 1.3 within frequency region 110-170 GHz.
- 3.8. The limit of instability of the output power level of unmodulated oscillation at the unchanged environment and primary power voltage during any 15 min of work is ±0.3dB (the warm-up time after adjustment from one frequency to another must be no less than 5 min).
- 3.9. Admissible variation of output power level of unmodulated oscillation at slow 10% variation of primary power voltage for AC 50Hz, is no more than ±0.5dB.
- 3.10. 50 Hz AM level of output CW signal is no larger than 1%.
- 3.11. VSWR of output of the Generator is no more than 1.5:1 at the 1 mW output power.

- 3.12. Output waveguide WR-06.
- 3.13. Waveguide flange UG-387/U-M.
- 3.14. Internal square-wave modulation frequency, kHz 1-100.
- 3.15. External square-wave modulation frequency, kHz 1-100.
- 3.16. External Power Control Voltage, V 0...+10.
- 3.17. External Frequency Control Voltage, V +2.4...+7.6
- 3.18. Operating modes CW:

Remote frequency and power regulation by an analogue voltage, frequency and power regulation from front panel and GPIB interface.

- 3.19. Electrical resistance between primary power line and the cabinet is no less than 100 Mohm; at high humidity – no less than 3 Mohm; at high temperature – no less than 5 Mohm.
- 3.20. All parameters mentioned above are valid after 30-min warming-up period.
- 3.21. Power consumption is no more than 400 VA.

4. RELIABILITY

- 4.1. Main time to failure, no less than 2000 h.
- 4.2. 90% life time, no less than 1 year.

5. CONSTRUCTIVE PARAMETERS

- 5.1. Dimensions 495x180x480 mm.
- 5.2. Weight, no more than 23 kg.

6. PRINCIPLE OF OPERATION

Generator is made up of the oscillator unit, control unit, modulator unit and power supply unit (Supplement. 3).

Oscillator unit is made up of BWO and high voltage isolator. BWO intended to generate UHF oscillations. High voltage isolator intended to isolate the BWO's cabinet being kept under high voltage, from grounded output waveguide.

Control unit is based on PC microcomputer. It is used together with digital to analogue converter as triangle wave voltage oscillator, for digital remote control of generator from front panel or by means GPIB bus.

Power supply unit includes the following parts. Controlled high voltage source for accelerating electrode of BWO. Controlled 5...230 V DC voltage intended to feed the modulator and BWO control electrode. DC 1.2 V voltage source intended to feed the BWO heater. DC +16 and –16 V voltage sources intended to feed OA's. DC +5 V voltage source intended to feed computer and relays. BWO current overload protection circuit intended to switch off the high voltage transformer, if load current of decelerator power supply is larger than 50 mA. Control voltage overload protection circuit is intended to switch off the BWO control electrode voltage, if deceleration voltage is lower than 300 V. This circuit allows also the BWO control electrode voltage to be supplied, if only the deceleration voltage higher than 300 V is presented on BWO's deceleration electrode, when the Generator is being turning on. BWO heater current overload protection circuit intended to limit the BWO heater current at the current spikes in the moment of Generator turning on. High voltage indication "READY" (3) circuit intended for signalling if decelerating voltage source is switched on.

Modulator unit intended to modulate amplitude of output signal depending on operating mode.

On the front panel of generator are installed the following controls (see Supplement 1):

Button “Power” (1) to turn on the generator and indicator “Power” to indicate condition of generator.

Liquid Crystal Display for indication of various regimes of Generator (5).

Tuning knob for frequency and power setting (6).

Two buttons for fine setting of frequency or power (7).

Digital Keyboard (8), Functions Keyboard (11-14).

Button “Power Control”(14) switches External or Internal Power Control modes. If LED on the button is glow it means that External Power Control mode is switched on. In External Power Control mode 0...+10VDC control voltage should be applied to the corresponding socket “Power Control” (20 on the Rear Panel) for a remote electrical manipulation of output BWO’s power. In Internal Power Control mode the power is controlled by microcomputer using DAC.

Button “Frequency Control” (11) switches External or Internal Frequency Control modes. If LED on the button is glow it means that External Frequency Control mode is switched on. In External Frequency Control mode +2.4...+7.6VDC control voltage should be applied to the corresponding socket “Input” (10) for a remote electrical manipulation of output BWO’s frequency. In Internal Frequency Control mode the frequency is controlled by microcomputer using DAC.

Buttons “Amplitude Modulation” (13) switch on different modes of amplitude modulation: CW (“OFF” button), Internal Amplitude Modulation (“Internal” button), Amplitude Modulation with External Triggering (“External” button). TTL signal from an external pulse generator should be applied to corresponding plug “AM Input” (19 on the Rear Panel) for the triggering of External Amplitude Modulation mode.

Button “Reset” restarts built-in microcomputer (4).

Button “Menu” calls operation menu to LCD (12).

“INPUT PLL” (15) is intended for keeping the BWO frequency constant is used, the external control signal has to be added to cathode voltage.

Knob “GAIN” (15) set sensitivity to external PLL system.

On the rear panel of generator the following controls are installed (see Supplement 2):

“Operating Time” counter (21);

“GPIB” for connecting the Generator to GPIB bus (22);

Ground socket (23).

Fuses (24 and 25);

“Power Plug” AC 220V (26);

“High Voltage Monitor” output plug (27) intended for an external checking up the frequency of the oscillation. Dependence of High Voltage Monitor output voltage versus frequency of oscillations is supplied in Supplement 8.

“Strobe AM signal”, output plug (TTL) (28);

“Strobe FM signal”, output plug (TTL) (29).

BWO is a heart of the Generator. Electrical Scheme of BWO is presented in Supplement 9. The Generator is functioning properly, if the following conditions are met:

- When turning on the power, the current spikes must be restricted;
- BWO control electrode voltage should appear if only deceleration voltage is present, and must be switched off in the opposite case;
- BWO control electrode voltage must not be higher than 237V.

BWO is a source of UHF oscillations, which a voltage of the decelerating system (Anode Voltage) controls frequency, and output power is controlled by a voltage applied to the control electrode.

BWO is connected in a grounded-cathode circuit. In this case the output waveguide of the BWO, as well as its cabinet, has a high electric potential relative the Generator cabinet, so the special high voltage isolator is used to isolate the BWO's output waveguide from the Generator's cabinet.

Setting the proper voltage on the BWO decelerating system provides the setting of the Generator's frequency. For this purpose the circuit is used which consists of the next parts:

- commutator;
- control unit;
- controlled high voltage source;
- BWO decelerating system.

Commutator provides a connection between control input of the High voltage power supply and external broadband frequency tune input (10), if "External Frequency Control" (11) is switched on.

Commutator provides a connection between control input of the High voltage power supply and control unit output, if "External Frequency Control" (11) is switched off.

Control unit provides:

- Linear control voltage with different full band Sweep Times (0.01, 0.02, 0.04, 0.08, 0.1, 0.2, 0.4, 0.8, 1, 2, 4, 8, 10, 20, 80, 100 Sec) in sweep frequency mode (see Supplement 6);
- Fixed DC voltage in fixed frequency mode.

There are two possibilities of the Control unit programming:

- Manual control, using front panel controls;
- Remote control, using GPIB bus.

Built-in microcomputer serves an indication of Initial and Final frequencies on the LCD display (5). The computer calculates corresponding frequency from the code of DAC that serves frequency control, using a calibration file "frequen.dat". Please refer to supplement 5. This file contains 4096 lines. Each line presents frequency at maximum output power corresponding digital to analogue converter code from 0 till 4095. At smaller output power the operation frequency is shifted a bit from the position corresponded to the maximum output power. Frequency shift between values at maximal and minimal power is about 1 GHz. Frequency shift is calculated by formula and used by microcomputer for indication of actual frequency. For example, initial and final frequencies of the sweep indicated on LCD are calculated this way.

Operating regime of the Generator is defined by BWO control electrode voltage (grid). In the CW regime this voltage is constant. In the Internal or External Amplitude Modulation regimes, this voltage is also symmetric rectangular pulse sequence with amplitude equal to the constant voltage in CW regime. In the External Power Control regime the voltage is user defined. In all regimes voltage applied to BWO control electrode must not exceed 237V.

The operating regime of the Generator is defined by a joint functioning of the next parts of the device:

- Operating regime switch;
- Modulator;
- 5-237 V controlled voltage source;
- BWO control electrode.

The BWO current overload protection circuit receives the signal proportional to the decelerating system current. When this current is larger than 50 mA, the circuit comes into action and disconnect the high-voltage transformer. In order to switch the high voltage source again, it is necessary to turn off and then turn on the power switch. The high incidence of activation of this circuit testifies that Generator is out of order.

The BWO control voltage overload protection circuit receives the signal proportional to the BWO decelerating system voltage. This circuit is a part of the modulator circuit. When BWO decelerating voltage falls down below 300 V, the BWO control electrode voltage is switched off. In particular, this circuit comes into action when high voltage transformer is switched off.

The BWO heater overload protection circuit is a part of heat stabiliser circuit. It provides the limitation of BWO heater current during the transition process at the turning on the Generator.

7. OPERATION MANUAL

ATTENTION! Before turning on the Generator, ensure that device is properly grounded using the corresponding contact “⊥”.

When using the Generator connected with other electrical devices, the potentials of Generator and other devices must be equalised before the power is turned on. Mentioned actions are not needed if you are sure, that the device is grounded in primary power plug.

It is prohibited to turn on the Generator unless a waveguide with a load is attached to the output waveguide of the Generator!

8. HOW TO TURN ON THE GENERATOR

- Ground the Generator.
- Ensure that fuses are present.
- Attach a load to the output of Generator.

- Turn on the power. The “Power ON” indicator (2) must glow and in approximately 40s “READY “ indicator (3) must glow as well. On LCD (5) a current time will be indicated and after about 4s the main menu will be activated.
- All settings are stored automatically in flash memory of microcomputer. Generator loads automatically last settings after switch on or restart. Every time the “10%” power level will be installed after the tuning on the Generator to avoid possible problems with high power output. User should to install the higher power level, if it is needed in the experiment. Warm-up time is approximately 30 min.

9. PURSUANCE OF MEASUREMENTS

There are two operating menus witch are controlled by “Menu” button (12):

- Main Menu.
- Sweep Menu.

“Main Menu” consists of:

1. Freq _____ GHz
2. Power _____ %
3. AM _____ kHz
4. GPIB adr _____
5. Save program
6. Load program

“Sweep Menu” consists of:

1. Sfreq _____ GHz
2. Efreq _____ GHz
3. Time _____ s
4. Width _____ GHz
5. Sweep Start
6. Zoom Start

9.1 Frequency control

There are two modes of frequency: Internal and External Frequency Control modes. Turn on the Generator as directed in part 8.

9.1.1 Set Internal Frequency control mode.

One should check LED “External” on the button “Frequency Control” (11). If LED doesn’t glow, it means that the device is installed in Internal Frequency Control mode. If LED glows, one should press button “Frequency Control” to switch off LED on the button (11).

A. Fixed frequency mode.

At this mode the operation frequency is fixed.

Turn on the Generator as directed in part 8.

Set Internal Frequency control as described in par. 9.1.1.

Press button “Menu”(12) to active the “Main Menu”, then using buttons “Step” “<-“ or “->” (7) or Rotate Tuning Knob (6) install marker opposite point “1 Freq _____ GHz” of “Main

Menu” and press key “Enter” on keyboard (8) for put in the setting regime of frequency. One can press key “1” to active of this regime directly.

To enter the desired frequency one has three possibilities:

- Rotate Tuning Knob (6) and then press key “Menu” (12). Output operation frequency changes synchronously with value indicated on the display;
- Press buttons “Step” “<-“ or “->” (7) and then press key “Menu” (12). This way is useful if it is necessary to provide precision tuning. One button realising leads to the change of the frequency on the smallest available step. Output operation frequency changes synchronously with value indicated on the display;
- Enter frequency from Digital Keyboard (8). A marker will appear on the display just after the realising of one of the keys (8). One can use buttons “Step” “<-“ or “->” (7) to change the marker position. That allows edit the frequency on the display. Press key “Enter” to finish editing and change the output operation frequency. If one will try to enter a wrong frequency, out of operating frequency range, max or min one available will be installed correspondingly.

One can combine these three cases.

If one enter the frequency using Digital Keyboard, Generator sets the nearest frequency from frequency grid that reflects the fact that output voltage of controlling 12-bits DAC’s can’t be installed with accuracy better then 1/4096. If one try to enter a frequency that isn’t fitted to the grid exactly, the fitting will be produced automatically.

B. Frequency sweep mode.

In this mode Generator provides frequency sweep from the initial frequency to final one. User would program both frequencies, power and time of sweep. The sweep is provided by saw-tooth voltage. During Sweep Time Control Unit provides linear increasing of control voltage and then fast voltage decreasing during approximately 1 ms time. Pay attention that the sweep is provided by linear increasing control voltage, but frequency increases according the dependence of frequency versus control voltage that presented in Certification Card (see Supplement 8).

Set the desired sweep time, initial and final frequency.

Turn on the Generator as directed in part 8. Set Internal Frequency control as described in par. 9.1.1. Press button “Menu”(12) to activate the “Sweep Menu”.

There are the following commands in this local menu:

1. SFreq _____ GHz – set Initial Frequency;
2. EFreq _____ GHz – set Final Frequency;
3. Time _____ s – set sweep time;
4. Width _____ GHz – set zoom width;
5. Sweep Start – start sweep;
6. Zoom Start – start zoom mode.

To enter desired value of sweep time, Initial and Final frequencies to use method described in par. 9.1.1A.

In the case of Sweep Time, only one of the following values could be installed: 0.01, 0.02, 0.04, 0.08, 0.1, 0.2, 0.4, 0.8, 1, 2, 4, 8, 10, 20, 80, 100 Sec. If one try to enter a value that isn’t fitted to the grid exactly, the fitting will be produced automatically.

To start sweep press key “2” on Digital Keyboard (8). Generator indicates initial and final frequencies of sweep and starts sweeping. At the beginning of each sweep Generator produces TTL strobe pulses. Use Strobe Signal output plug (29) for the triggering of external devices at the moment of the sweep beginning (see Supplement.6).

To stop sweep press key “Menu”.

C. Zoom frequency window mode.

In this mode Generator provides frequency sweep in the vicinity of fixed frequency (See par. A). User would program zoom window width (0.25, 0.5, 1.0 or 5.0 GHz) and time of sweep. The sweep is provided by saw-tooth voltage. Control Unit provides linear increasing of control voltage during Sweep Time and then fast voltage decreasing during approximately 1 ms time. Pay attention that the sweep is provided by linear increasing control voltage, sweep frequency range is small and linear approximation of the frequency dependence versus control voltage is taken into account within zoom window.

Turn on the Generator as directed in part 8. Set Internal Frequency control as described in par. 9.1.1. Press button “Menu”(12) to activate the “Sweep Menu.

There are four commands in this local menu:

1. SFreq _____ GHz – set Initial Frequency;
2. EFreq _____ GHz – set Final Frequency;
3. Time _____ s – set sweep time;
4. Width _____ GHz – set zoom width;
5. Sweep Start – start sweep;
6. Zoom Start – start zoom mode.

To enter desired value of zoom time and width to use method described in par. 9.1.1A.

In the case of Sweep Time, only one of the following values could be installed: 0.01, 0.02, 0.04, 0.08, 0.1, 0.2, 0.4, 0.8, 1, 2, 4, 8, 10, 20, 80, 100 Sec. If one try to enter a value that isn't fitted to the grid exactly, the fitting will be produced automatically.

In the case of Width, only one of the following values could be installed: 0.25, 0.5, 1 or 5 GHz. If one try to enter a value that isn't fitted to the grid exactly, the fitting will be produced automatically.

To start the zoom one should press key “6” on Digital Keyboard (8). Generator will indicate central frequency of sweep. At the beginning of each sweep Generator produces TTL strobe pulses. Use Strobe Signal output plug (29) for the triggering of external devices at the moment of the sweep beginning (see Supplement 6).

To stop sweep press key “Menu”.

9.1.2 Set External Frequency control mode.

One should check LED “External” on the button “Frequency Control” (11). If LED glows, it means that the device is installed in External Frequency mode. If LED doesn't glow, one press button “Frequency Control” to switch on LED on the button (11).

In this mode an external positive voltage +2.4...+7.6 VDC controls output frequency of Generator. Feed the positive +2.4...+7.6 VDC voltage into the plug “Input” (10) “External Frequency Control”. The applied voltage corresponds to output frequency according to calibration table (see Supplement 8).

9.2 Power control

There are two modes of Power: Internal and External Power Control modes. Turn on the Generator as directed in part 8.

9.2.1 Set Internal Power control mode.

One should check LED “External” on the button “Power Control” (14). If LED doesn’t glow, it means that the device is installed in Internal Frequency Control mode. If LED glows, one should press button “Frequency Control” to switch off LED on the button (14).

To enter desired value of Output Power to press button “Menu”(12) to activate the “Main Menu”. Using buttons “Step” “<-“ or “->” (7) or Rotate Tuning Knob (6) to install marker opposite point “2 Power _____ %” of “Main Menu” and press key “Enter” on keyboard (8) for put in the setting regime of Output Power. One can press key “2” to active of this regime directly.

To enter the desired Output Power one has three possibilities:

- Rotate Tuning Knob (6) and then press key “Menu” (12). Output Power changes synchronously with value indicated on the display;
- Press buttons “Step” “<-“ or “->” (7) and then press key “Menu” (12). This way is useful if it is necessary to provide precision tuning. One button realising leads to the change of the frequency on the smallest available step. Output Power changes synchronously with value indicated on the display;
- Enter Output Power from Digital Keyboard (8). A marker will appear on the display just after the realising of one of the keys (8). One can use buttons “Step” “<-“ or “->” (7) to change the marker position. That allows edit the power on the display. Press key “Enter” to finish editing and change the output power. If one will try to enter a wrong power, out of 0-100% range, max or min one available will be installed correspondingly.

One can combine these three cases.

In the case setting of Power Level, the grid is defined in percents of voltage applied to Control Electrode of BWO tube. In Supplement 4 dependencies of output power versus frequency for different voltage applied to control electrode (in percents) are presented. Control Unit indicates Output Power also in percents of control voltage applied, not in percents of real output power.

9.2.2 Set External Power control mode.

One should check LED “External” on the button “Frequency Control” (14). If LED glows, it means that the device is installed in External Frequency mode. If LED doesn’t glow, one press button “Frequency Control” to switch on LED on the button (14).

In this mode an external positive voltage 0...+10 VDC controls output power of Generator. Feed the positive 0...+10 VDC voltage into the plug “Input” (20) “External Power Control”. The higher voltage corresponds to the higher output power.

9.3 Amplitude Modulation.

There three mode:

- CW (OFF);
- Internal;

- External.

One should check LED on “Amplitude Modulation” group of buttons (13). If LED glows, it means that the device is installed in indicated mode.

9.3.1 Set CW mode (Amplitude Modulation is OFF).

Press button “OFF” in “Amplitude Modulation” group of buttons (13).

9.3.2 Set Internal Modulation Mode.

Press button “Internal” in “Amplitude Modulation” group of buttons (13) and square wave 100% amplitude modulation with frequency 1-100 kHz is provided to output. Use Strobe Signal output plug (28) for the triggering of external devices.

Turn on the Generator as directed in par. 8.

To enter desired value of frequency modulation to press button “Menu”(12) to activate the “Main Menu”. Using buttons “Step” “<-“ or “->” (7) or Rotate Tuning Knob (6) to install marker opposite point “3 AM _____ kHz” of “Main Menu” and press key “Enter” on keyboard (8) for put in the setting regime of Output Power. One can press key “3” to active of this regime directly.

To enter the desired AM frequency one has three possibilities:

- Rotate Tuning Knob (6) and then press key “Menu” (12). AM frequency changes synchronously with value indicated on the display;
- Press buttons “Step” “<-“ or “->” (7) and then press key “Menu” (12). This way is useful if it is necessary to provide precision tuning. One button realising leads to the change of the AM frequency on the smallest available step. AM frequency changes synchronously with value indicated on the display;
- Enter AM frequency from Digital Keyboard (8). A marker will appear on the display just after the realising of one of the keys (8). One can use buttons “Step” “<-“ or “->” (7) to change the marker position. That allows edit the AM frequency on the display. Press key “Enter” to finish editing and change the AM frequency. If one will try to enter a wrong frequency, out of operating frequency range, max or min one available will be installed correspondingly.

In the case of AM, only fixed values could be installed. PC main board counter (2MHz/x) provides these values. If one try to enter a value that isn’t fitted to the grid exactly, the fitting will be produced automatically.

9.3.3 Set External Amplitude Modulation.

Press button “External” in “Amplitude Modulation” group of buttons (13) and square wave 100% amplitude modulation with frequency of an external triggering source is provided in this mode. Feed the 5 V (TTL) positive pulses with a frequency in the range 1-100 kHz and duty ratio 2 (square wave) into the “AM Input” (19). After that Generator will provide amplitude modulation with frequency of the triggering signal.

9.4 Set device address on GPIB bus.

GPIB interface card integrated into Controller is initialised automatically in device (slave) mode. One can set Generator's address on GPIB bus from 01 till 20. Generator saves GPIB address in flash memory and installs it automatically after restart.

Set new GPIB address for example 12, assuming that present address is 19. Press button "Menu" to activate "Main menu" of GPIB address setting. Press key "4" and then press keys "1","2" to enter new address 12. After press "Enter" new address will be installed. If one would like to install address 1 he should enter "0" "1" in series.

9.5 Save and load operation set-up.

Generator automatically saves all settings from par. 9.1 - 9.4 just after one changes these. Current set-up is stored in memory and loaded after restart. There are 10 user defined operation set-ups stored in flash memory. Each set-up consists of the following settings:

- Initial frequency;
- Final frequency;
- Fixed frequency;
- Output power level;
- Sweep time;
- Zoom width;
- External of Internal Frequency control mode;
- External of Internal Power control mode;
- External, Internal or OFF amplitude modulation mode
- GPIB address.

- Save current settings in flash memory.

Only last settings are stored and then loaded in the device automatically. If one would like to store some special set-up, he should to install desire settings as described in par. 9.1-9.4. Then one should enter to main menu. Press the button "Menu" (12), if it is needed.

Press key "5" on Digital Keyboard (8) to activate command "Save Program" from main menu. Choose number of program from "0" to "9" pressing the corresponding key on Digital Keyboard (8). The current set-up will be stored.

- Load set-up from flash memory.

If one would like to load set-up saved in flash memory, he should enter to main menu. Press the button "Menu" (12), if it is needed. Press key "6" on Digital Keyboard (8) to activate command "Load Program" from main menu. Choose number of set-up from "0" to "9" pressing the corresponding key on Digital Keyboard.

9.6 Test parameters of BWO tube.

This mode allows measure actual operating voltages and currents for BWO tube:

1. "Uheat" – Heating Voltage;
2. "Iheat" – Heating Current;
3. "Ugrid" – Grid Voltage;
4. "Ianode" – Anode Current;
5. Pwr control – setting Power control Mode;
6. Amp Modulat – setting AM Mode;
7. Frq control – setting Frequency Control Mode.

- Press key “.” on Digital Keyboard (8) to active “Additional Menu”.
- On LCD screen appears information about operating current and voltage for BWO tube and generator.

For example: “Uheat=1.17V Iheat= 1.9A”, “Ugrid=220V Ianode=30mA”, “Pwr Control Int”, “Amp Modulat OFF” and “Frq ControlInt”. “Ianode” is variable 3...48mA, “Ugrid” is variable 3...240V.

10. GPIB INTERFACE

All commands and settings would be controlled through GPIB interface. Connect the generator to GPIB bus (plug 22 on the rear panel) using special cable.

- Turn on the generator as directed in chap. 9 par.
- To control of Generator one should send ASCII symbols corresponded to the following table:

Name of Command	Symbols via GPIB port
Fixed Output Frequency	“F3xxx.xxx”
Initial Frequency	“F1xxx.xxx”
Final Frequency	“F2xxx.xxx”
AM Frequency	“F4xx”
Internal Frequency Control	“Fi”
External Frequency Control	“Fe”
Output Power Level	“P_xx”*
Internal Power Control	“Pi”
External Power Control	“Pe”
Amplitude Modulation External	“Ae”
Amplitude Modulation Internal	“Ai”
Amplitude Modulation Off	“O”
Sweep Time	“T_xx”*
Start Sweep	“G”
Stop Sweep	“S”
Zoom Width	“W_xxxx”*
Stop Sweep/Zoom	“S”

* “_” - symbol is blank.

The current the Generator settings may be read via GPIB bus in form of "Status String"="Name_F1_F2_F3_F4_PowerLevel_SweepTime_Width_Uheat_Iheat_Ianode_Ugrid_Condition". It consists of 6 information words separated with blanks. The "Status String" dimension is variable and depends on the current status of the Generator.

- The "Name" string occupies first six bytes, from 1st to 6th. For the Generator this string is fixed: "Name"="G4-143".
- The "Condition" occupies 4 bytes. Correspondence between values of each "Condition" bit and the Generator settings are shown in the next table:

Regime	Bit	Value
Power "Internal Control"	1	0
Power "External Control"	1	1
Amplitude modulation "External"	2	2
Amplitude modulation "Internal"	2	1
Amplitude modulation "OFF"	2	0
Frequency "Internal Control"	3	0
Frequency "External Control"	3	1
Sweep OFF	4	0
Sweep ON	4	1

Supplements

1. Front panel of the Generator

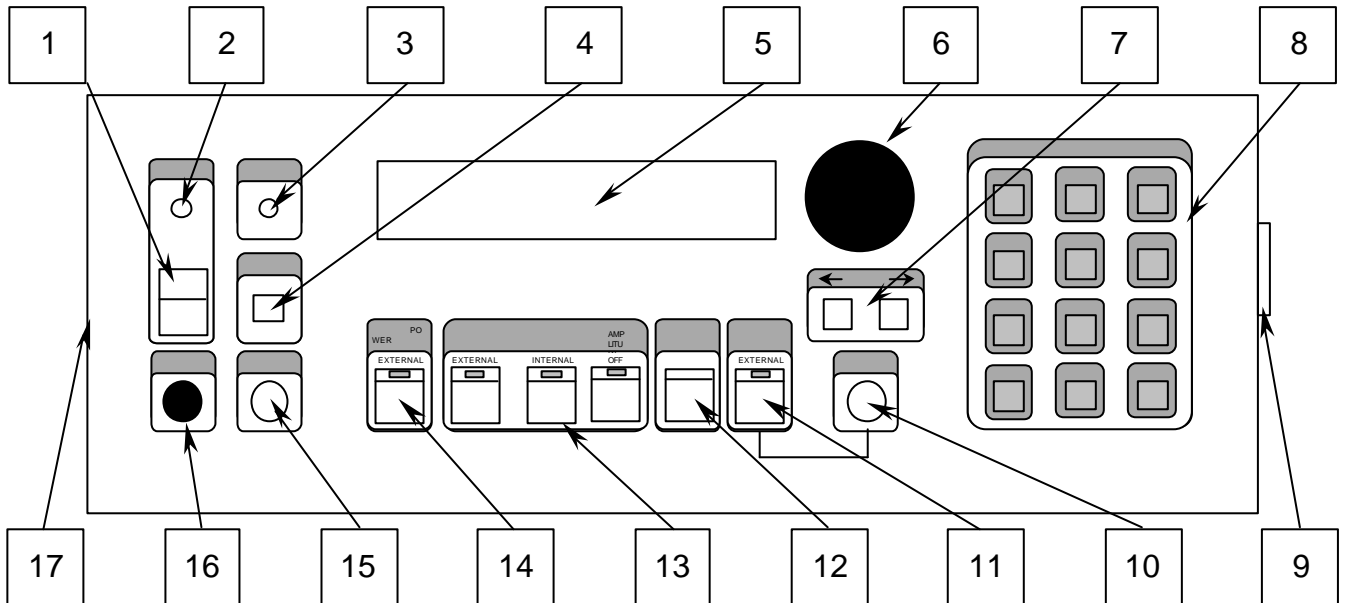

Disposition of the plugs and knobs on the front panel of the Generator.

1. "Power" switch.
2. "Power" indicator.
3. "Ready" indicator.
4. "Reset" button.
5. Liquid Crystal Display.
6. Tuning knob.
7. "Step" knobs.
8. Digital keyboard.
9. Microwave output.
10. External broadband frequency input (BNC connector).
11. External frequency control switch.
12. "Menu" button.
13. Amplitude modulation mode switches.
14. External power control switch.
15. Input for PLL system (BNC connector).
16. "Gain PLL" knob. Setting sensitivity to PLL system.
17. External VGA monitor and keyboard (under cover of left panel).

2. Rear panel of the Generator

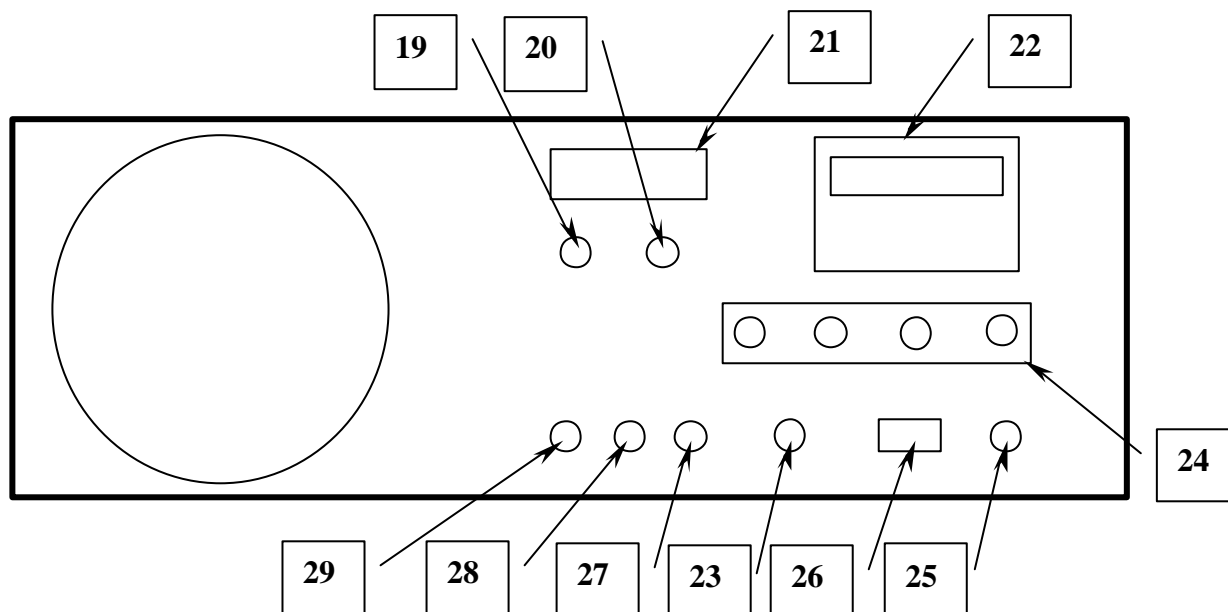

Disposition of the plugs and knobs on the rear panel of the Generator.

- 21. "AM INPUT", input for amplitude modulation (BNC connector)
- 22. "POWER CONTROL", input for control voltage of output power (BNC connector)
- 23. «Operating Time» counter.
- 24. «GPIB» interface plug.
- 25. Ground
- 26. Fuses.
- 27. Fuse 5A (protection +5V).
- 28. «Power Plug» AC 220V.
- 29. «High Voltage Monitor» output plug.
- 30. «Strobe AM signal», output plug (TTL).
- 31. «Strobe FM signal», output plug (TTL).

3. Disposition of the units in the Generator

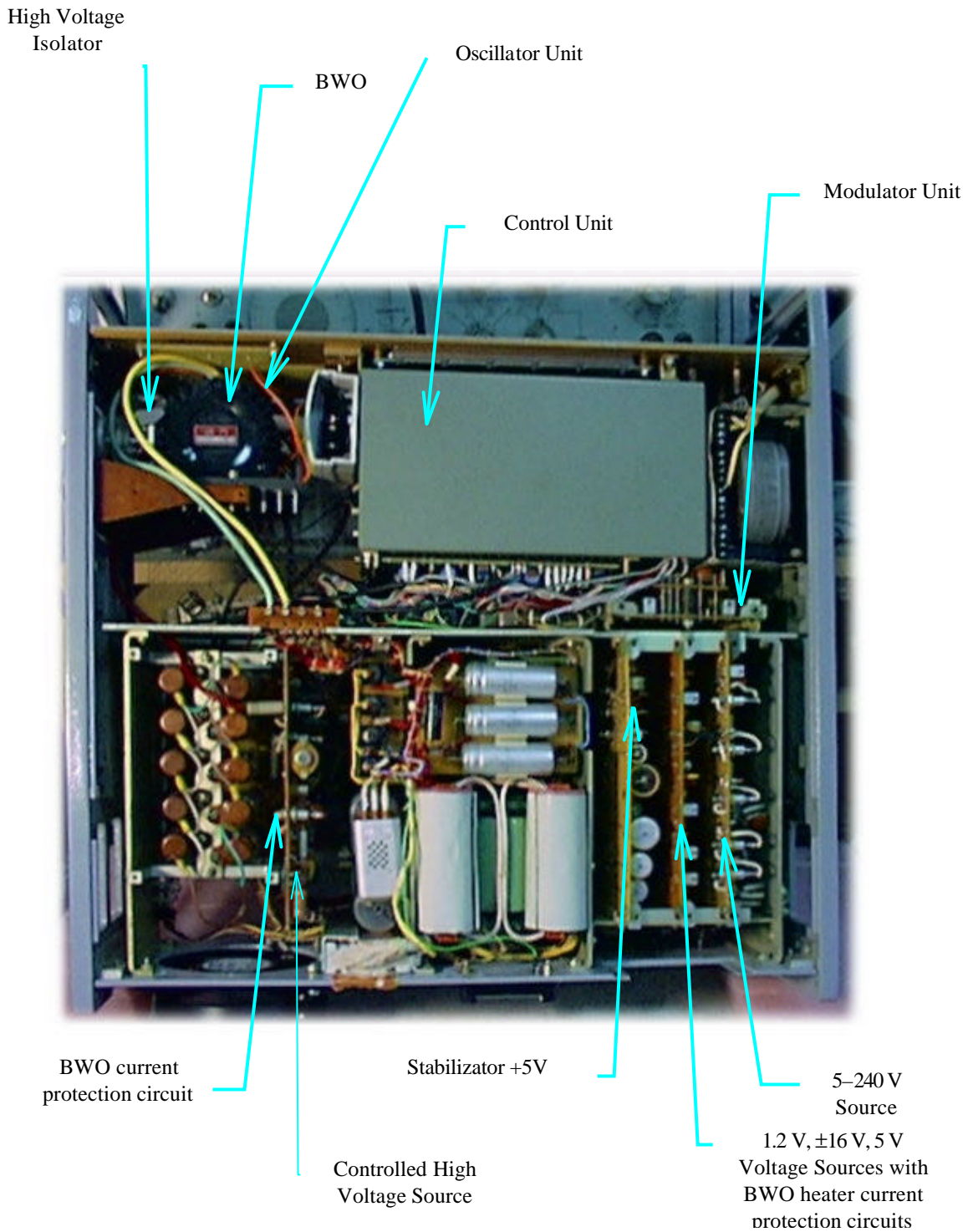

4. Block diagram of the control unit

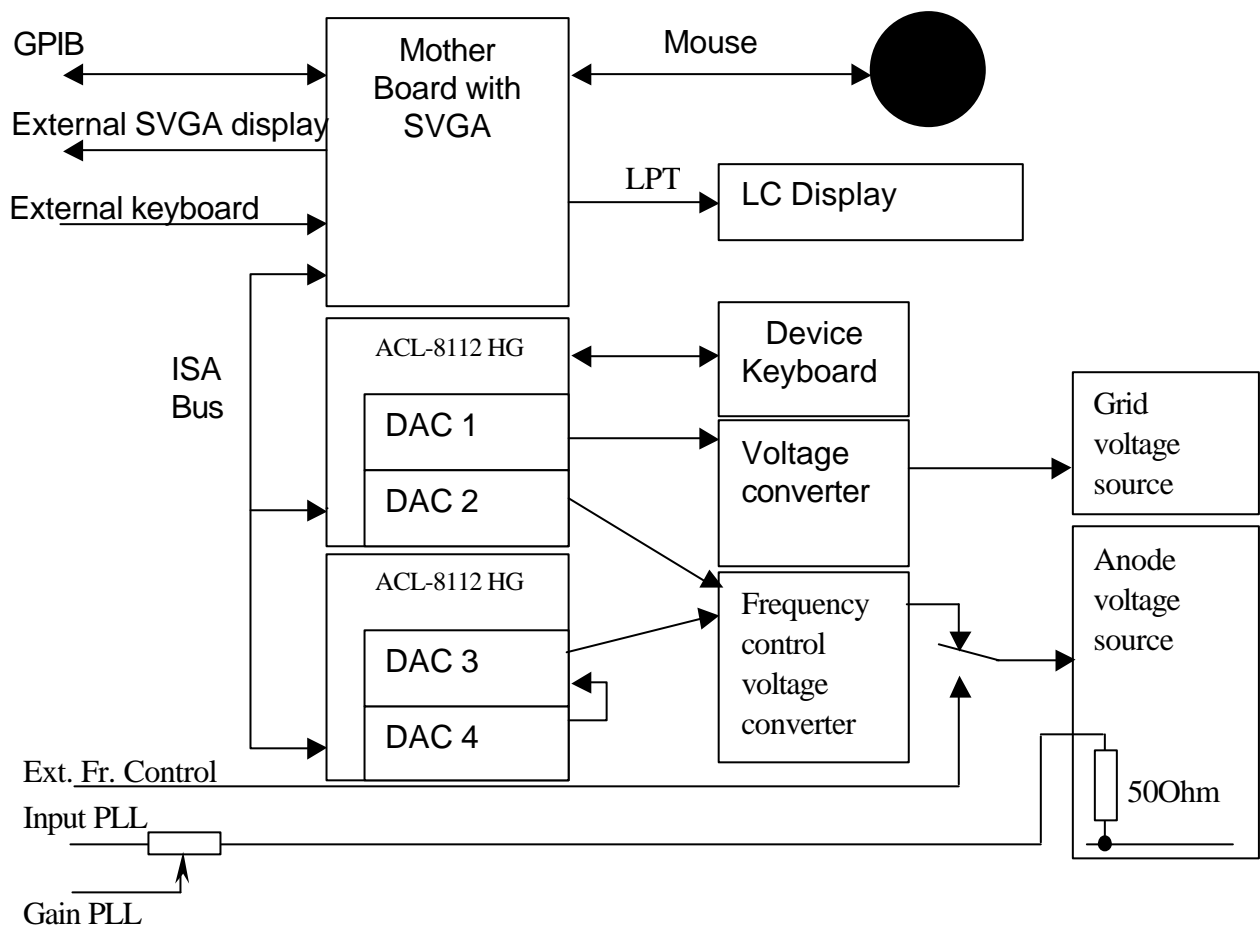

A simplified block diagram of the Computer Unit is shown on the plot. It includes: Mothers board Juky-730 Industrial Standard PC compatible microcomputer. There are four digital to analog converters in two data acquisition cards ACL-8112. DAC1 sets the amplitude of power control voltage; DAC2 sets the amplitude of frequency control voltage. It is used for full band sweep; DAC3 sets the amplitude of frequency control voltage in Zoom Sweep Window mode; DAC4 sets the reference voltage for DAC3. It allows change width of "frequency window" in zoom sweep mode. The device operates as follows. Built-in microcomputer and data acquisition cards provide voltage for power and frequency control. DAC1 is used for the regulation of voltage applied to control electrode (grid) of BWO and so for the control of the output microwave power. DAC2 is used for the regulation of voltage applied to anode of BWO and so for the control of the output frequency. Control voltage is constant in Fixed Frequency mode or triangle linear rise voltage in Sweep Frequency mode. DAC3 is used in Zoom Sweep Window mode. A constant voltage from DAC2 is added to triangle linear rise voltage produced by DAC3. Output voltage of DAC3 is divided on coefficient 1:20. DAC4 controls amplitude of Zoom Sweep. Circuit switches between various modes are provided by relays. Parallel port (LPT1) is used for control of liquid crystal display (LCD). RS-232 serial port (COM3) is "mouse" port. It serves the operation of tuning knob.

5. The structure of the calibration files.

We calibrate the output frequency of Generator through DAC2 (See. Supplement 4). We change DAC2 code from \$0000 till \$0FFF and measure output frequency at 100% Power Level. Maximum Power Level 100% corresponds to code \$0FFF in DAC1. Measured results are presented in file **frequen.dat**. This file is stored in flash memory of Control Unit.

Example.

There are 4096 strings in the file. Each string presents the frequency in GHz. Data presented at the first string corresponds to DAC2 code \$0000. The code is increasing on 1 with increasing of string number. For example, DAC2 code \$0006 corresponds to output frequency 106.14 GHz.

106.97
106.01
106.04
106.07
106.10
106.14
...

6. The diagram of the Control Voltage and strobos.

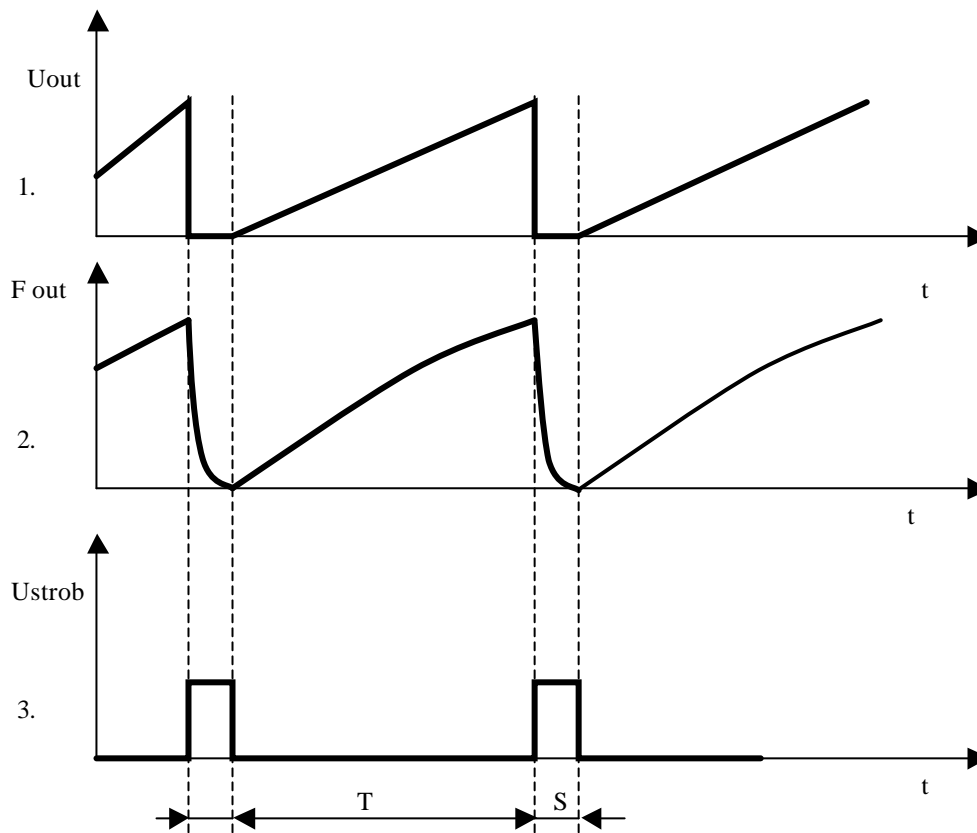

1. The diagram of the internal triangle wave control voltage on plug (27).
 2. The diagram of the output frequency.
 3. The diagram of TTL output strobe signal on plug (29).
- T – sweep time, set by Digital Keyboard (8) or by GPIB bus command.
S – strobe time, duration about 0.001 sec.

7. Output power versus frequency

Plot 1. Dependence of Output Power versus frequency by various Power Levels.

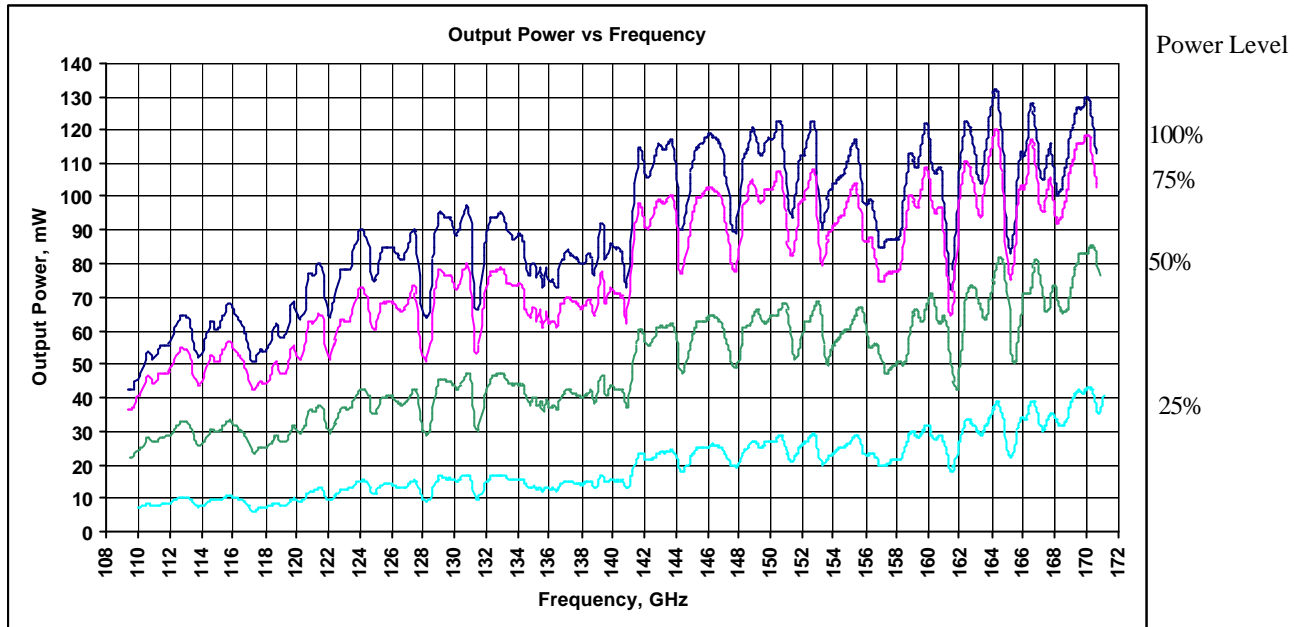

The structure of the calibration data.

The data in the calibration files are placed in ten columns divided by the tabs:

Uinp	HVm	P25	F25	P50	F50	P75	F75	P100	F100
2.4	2.842	7.3	109.937	22.1	109.511	36.4	109.324	42.1	109.293
2.405	2.847	7.3	109.955	22.1	109.526	36.4	109.334	42.1	109.298

- The first column (Uinp) is a control voltage in V, applying to the external broadband frequency input (10), see supplement 1;
- The second column (HVm) is a voltage in V, measured on the HV Monitor output plug (27), see supplement 2, corresponding to the data placed in the first column.
- The third column (P25) is measured output power of Generator in mW at 25 % power level, corresponding to the data placed in the first column;
- The fourth column (F25) is a Generator frequency in GHz at 25 % power level, corresponding to the data placed in the first columns;
- The fifth column (P50) is measured output power of Generator in mW at 50 % power level, corresponding to the data placed in the first column;
- The sixth column (F50) is a Generator frequency in GHz at 50 % power level, corresponding to the data placed in the first columns;
- The seventh and eighth columns (P75 and F75) correspond output power and frequency at 75% power level, corresponding to the data placed in the first columns;
- The ninth and tenth columns (P100 and F100) correspond output power and frequency at 100% power level, corresponding to the data placed in the first columns;

8. Frequency versus Control voltage, Frequency versus High voltage monitor

Plot 1. Dependence of voltage on the HV monitor output versus frequency at maximum level of output power.

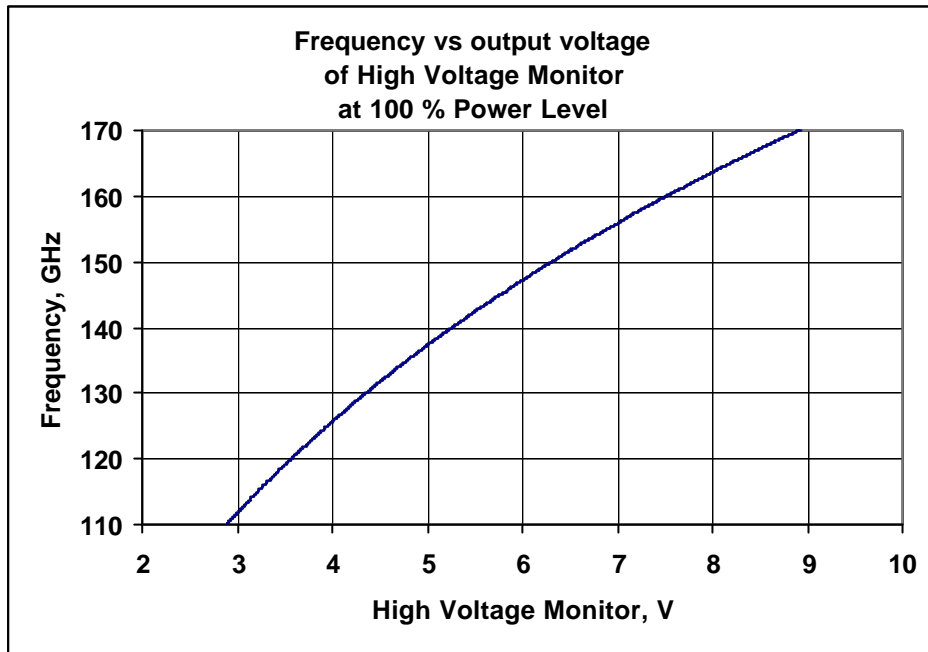

Plot 2. Dependence of frequency versus control voltage applied to the external broadband frequency tune input (10) at maximum level of output power.

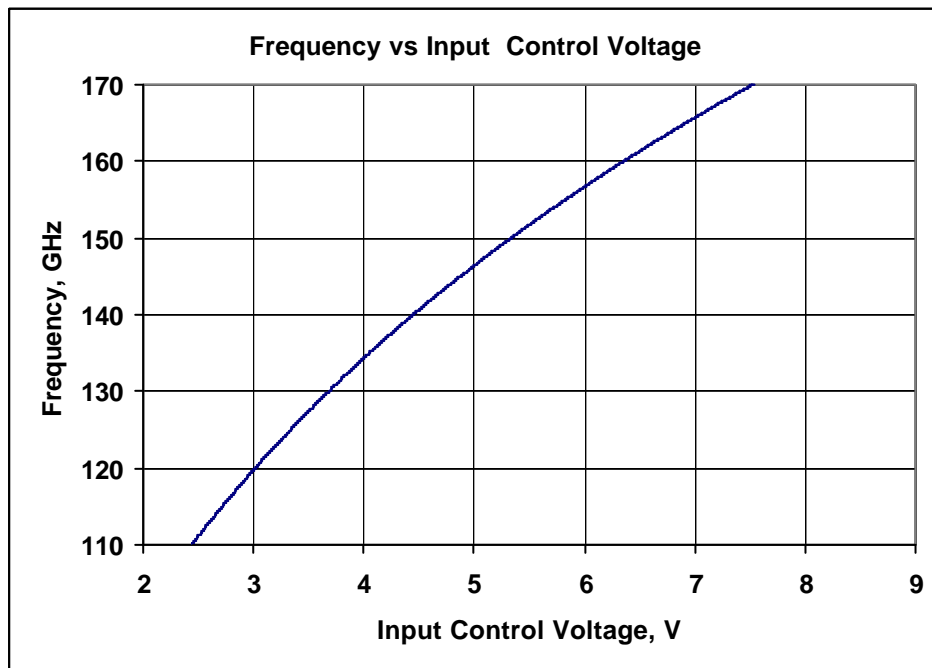

9. Electrical Scheme of BWO Tube

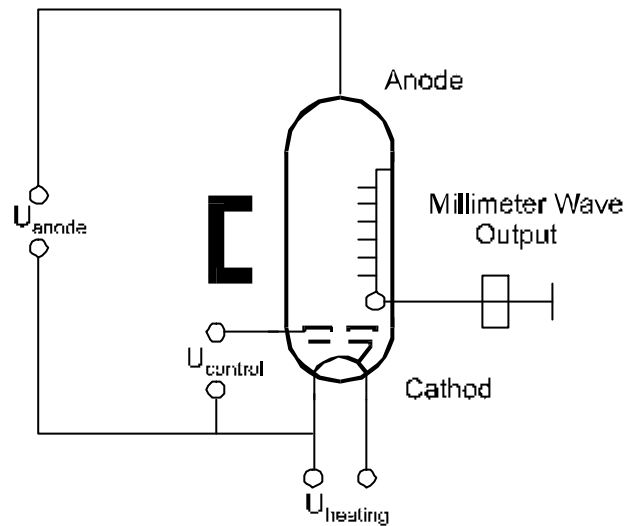

$U_{anode} = +500\text{VDC} \dots +2500\text{VDC}$,
 $U_{control} = +5 \dots +230\text{VDC}$,
 $U_{heating} = +1.0 \dots +1.2\text{VDC}$.