



46 Robezu str. LV-1004 Riga Latvia

Fax : +371-7-065102

Mm-wave Division in St. Petersburg, Russia

Fax: +7-812-326-10-60

Tel: +7-812-326-59-24

E-mail: korneev@exch.nnz.spb.su

113-153 GHz Radiometer

Technical Description and User Manual



St. Petersburg
(June 2000)

Contents

1. Introduction.....	3
2. Parameters and specifications	4
3. Design and principles of functioning	8
3.1 RF BLOCK OF THE RADIOMETER	8
3.2 IF BLOCKS OF THE RADIOMETER.....	11
3.3 IF POWER SUPPLY UNITS.....	14

1. Introduction

The multichannel 113-153 GHz Radiometer (below referred to as *Radiometer*) is intended for plasma electron temperature measurements in tokamaks. The fact is taken as a basis of the device that the intensity of the ECE 2nd harmonic is proportional to the electron plasma temperature in situations when the plasma can be considered as the black body for its own cyclotron radiation. The Radiometer is a superheterodyne receiver that picks up the plasma EC emission and produces 0...+10V analogue output signal proportional to the plasma emission power. The measurements are performed simultaneously in 32 frequency channels (i.e. radial points in the plasma) covering 113-153 GHz band that corresponds to magnetic field range from 2 to 2.7 T. Output signals are delivered in a form available to be stored in tokamak data acquisition system.

2. Parameters and specifications

- Principle of functioning: super heterodyne receiver with double frequency conversion.
- Input frequency band 113 ÷ 153 GHz
- Output Video amplifier frequency band 0.01 Hz ÷ 1 MHz
- Number of output frequency channels 32
- Detection limit of individual channels $(0.4 \div 4) \times 10^{-10} \text{ W}^*$
- Bandpass widths in individual channels 0.9 ÷ 1.2 GHz^{**}
- Maximum output voltage +10 V
- Input waveguide WR-6
- Waveguide flange UG-387/U-M
- Output connectors BNC
- Operating temperature +10°C...+40°C
- Power supply 220 V, 50 Hz
- Total gain factors (include not only signal amplification but signal reduction in directional couplers and losses at the frequency conversions as well) for every channel are presented in Figs.1, 2.

* The values are different in different channels. See Figs. 3, 4.

** The values are different in different channels. See Tables 1, 2, page 11.

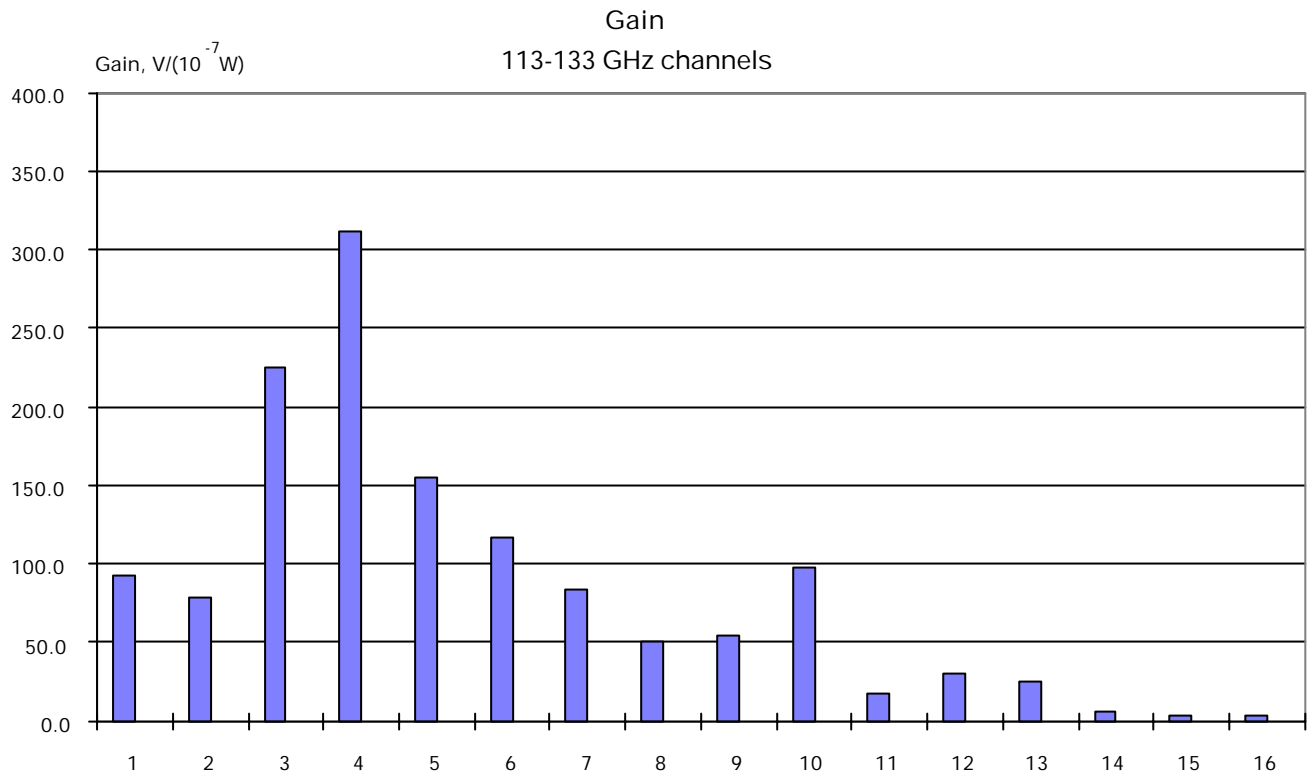

Fig. 1a. Total gain factor for 16 channels covering 113 to 133 GHz band.

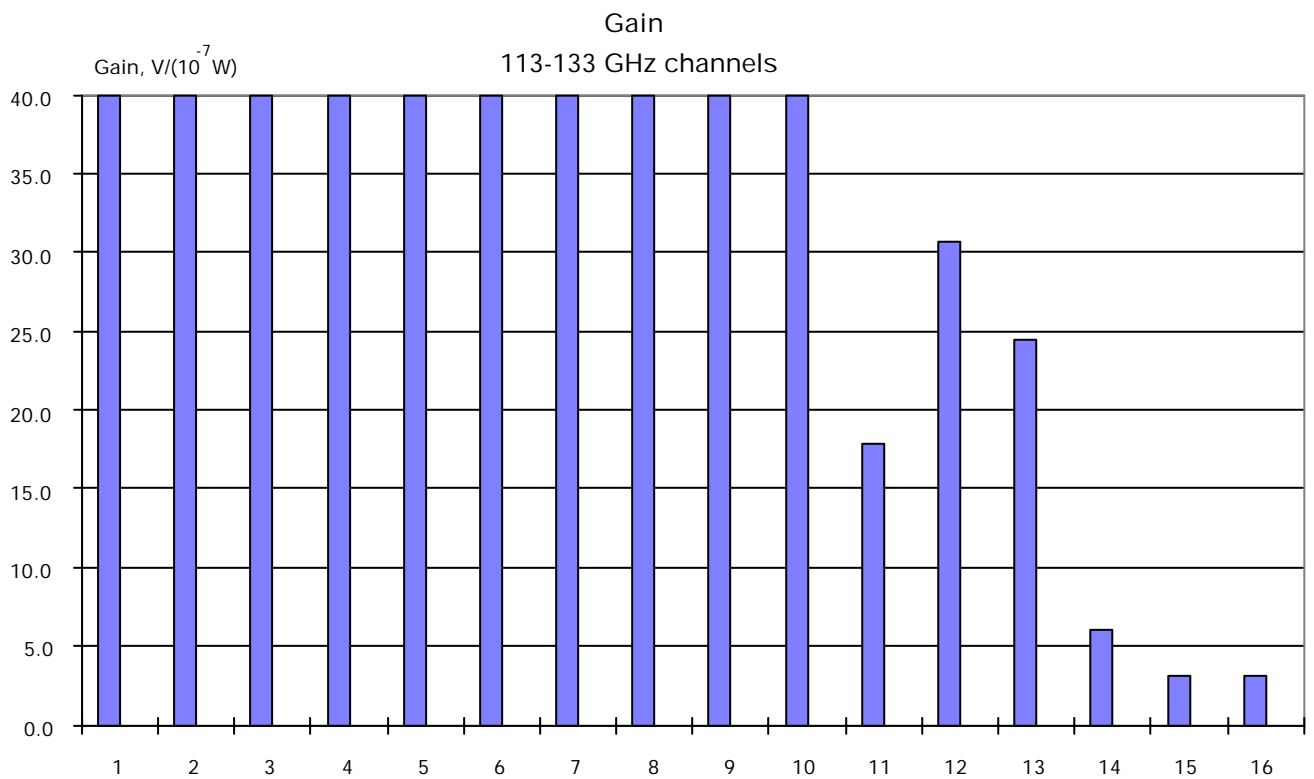

Fig. 1b. Total gain factor for 16 channels covering 113 to 133 GHz band (extended scale).

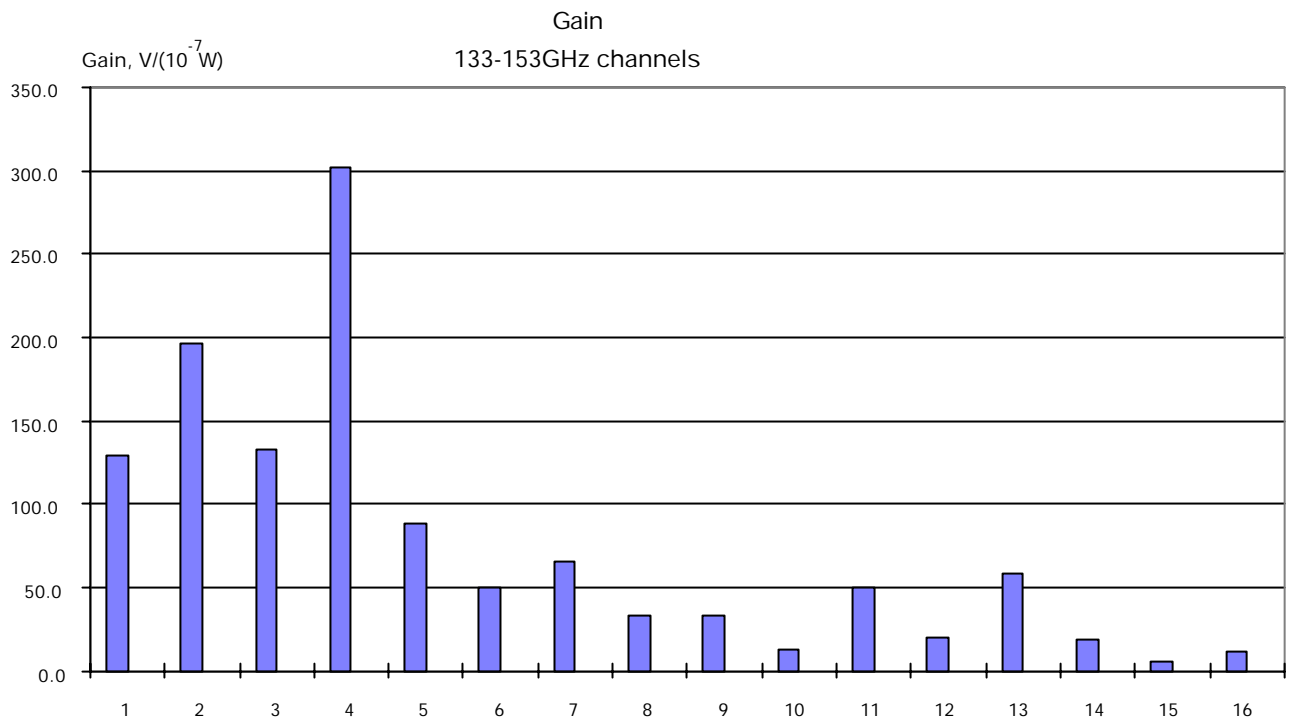

Fig. 2a. Total gain factor for 16 channels covering 133÷153 GHz band.

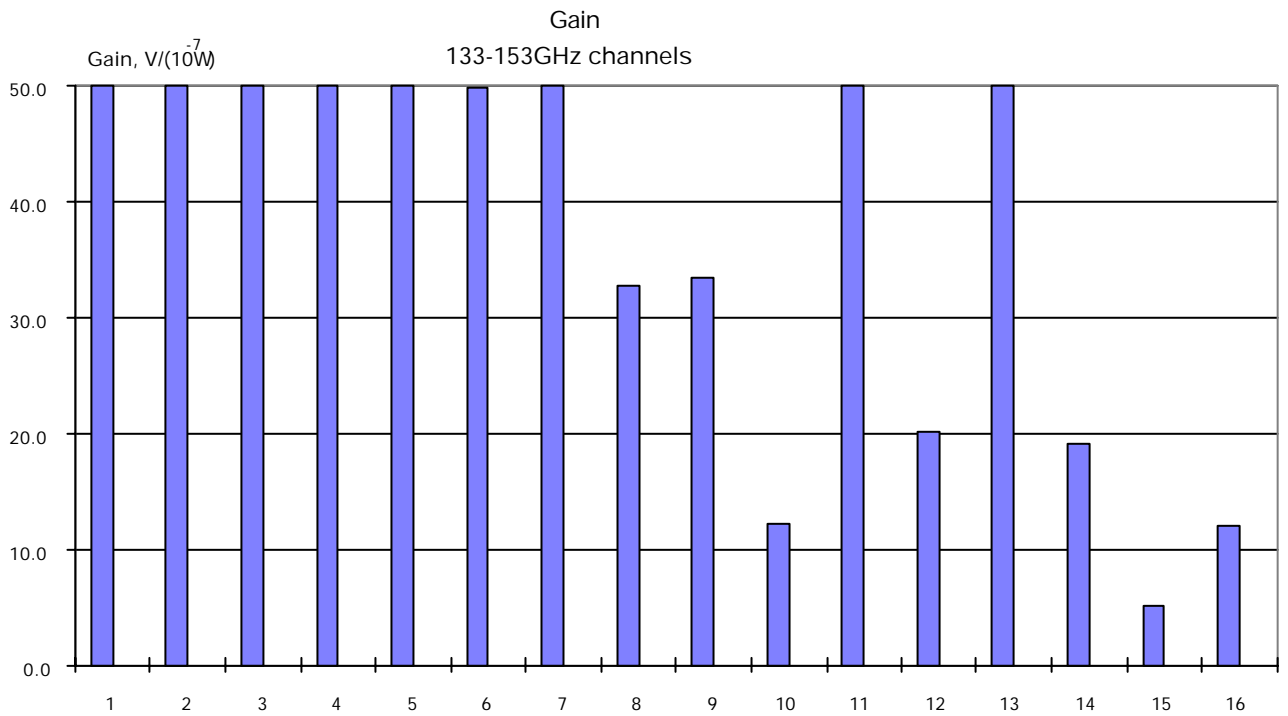

Fig. 2b. Total gain factor for 16 channels covering 133÷153 GHz band (extended scale).

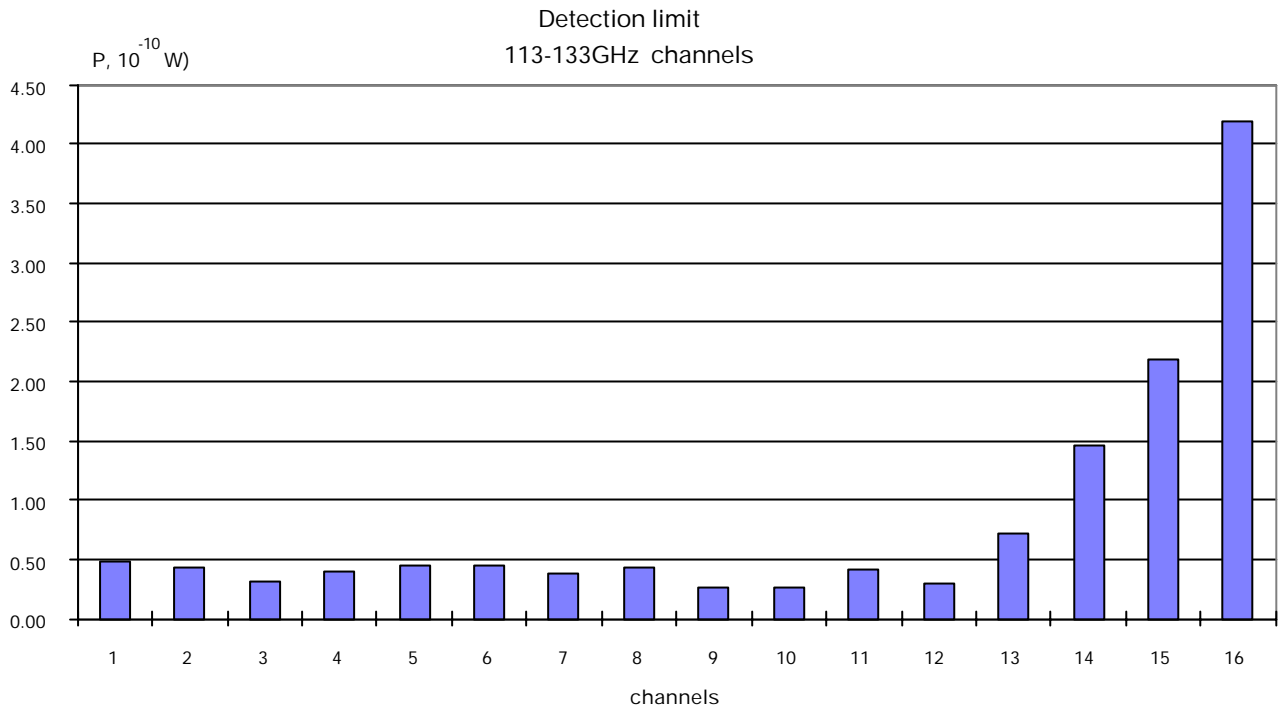

Fig. 3. Detection limit for 16 channels covering 113 to 133 GHz band.

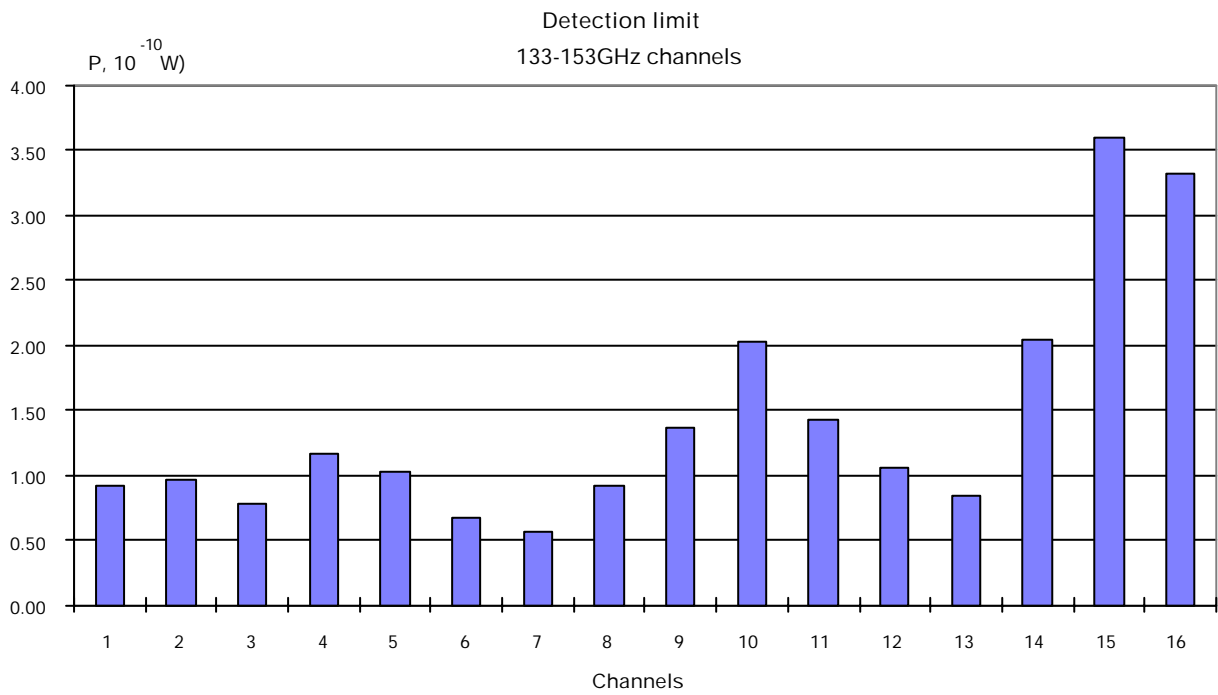

Fig. 4. Detection limit for 16 channels covering 133-153 GHz band.

3. Design and principles of functioning

The Radiometer consists of 5 separate blocks:

- Radio Frequency (RF) Block;
- two 16 channel Intermediate Frequency (IF) Blocks;
- two Power Supply Units for IF Blocks.

Block-scheme of the Radiometer is presented below:

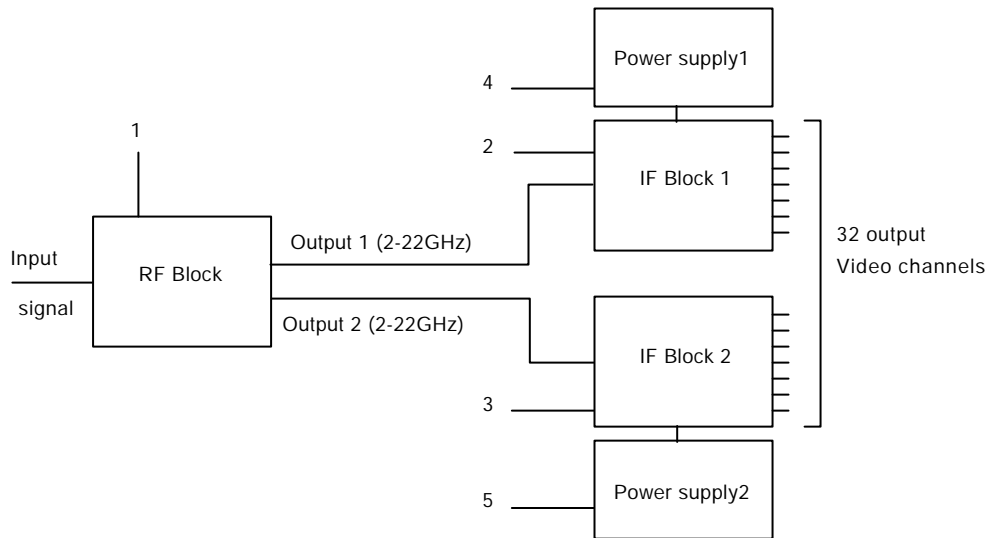

Fig. 5. Block-scheme of the Radiometer.

3.1 RF Block of the Radiometer

The RF Block destination is to perform first frequency conversion of the input 113÷153 GHz EC emission. The conversion is carried out by two Down Converters (DC), placed inside the Block; output frequency band is 2÷22 GHz for the both DC. Physical configuration of the RF Block is shown in Fig. 6. Its block scheme is presented in Fig. 7.

The plasma radiation passes through input waveguide and by means of 3-dB directional coupler (1, Fig. 7) is divided and directed into two channels. High pass waveguide RF filters (2 and 3, Fig. 7) are installed at the entrance of the both channels before wideband balanced Mixers (6 and 7, Fig.7) to cut off low frequency parts of the signal at 112 GHz for the first channel and at 132 GHz for the second one. Two cavity stabilized Local Oscillators (LO, see 4 and 5, Fig. 7) are used in the Down Converters, their frequencies being equal to 111 GHz and 131 GHz in correspondence to the channels.

Losses of the signal in the Mixers make up from 10 to 15 dB. To recoup them, Low Noise 2÷22 GHz band Amplifiers (LNA, see 8 and 9, Fig. 7) are incorporated in both the channels after the Mixers. Thus, 113÷133 GHz band of the input signal in the first channel and 133÷153 GHz band in the second one are converted in the same Intermediate Frequency (IF) band, 2÷22 GHz, in each of the channels. 89÷109 GHz and 109÷129 GHz low frequency "mirror" bands of the input signal are cut off by the

above mentioned high pass filters. Total (DC + LNA) conversion factors of both the channels are presented in Fig. 8 and 9.



Fig. 6. Outward appearance of the RF Block.

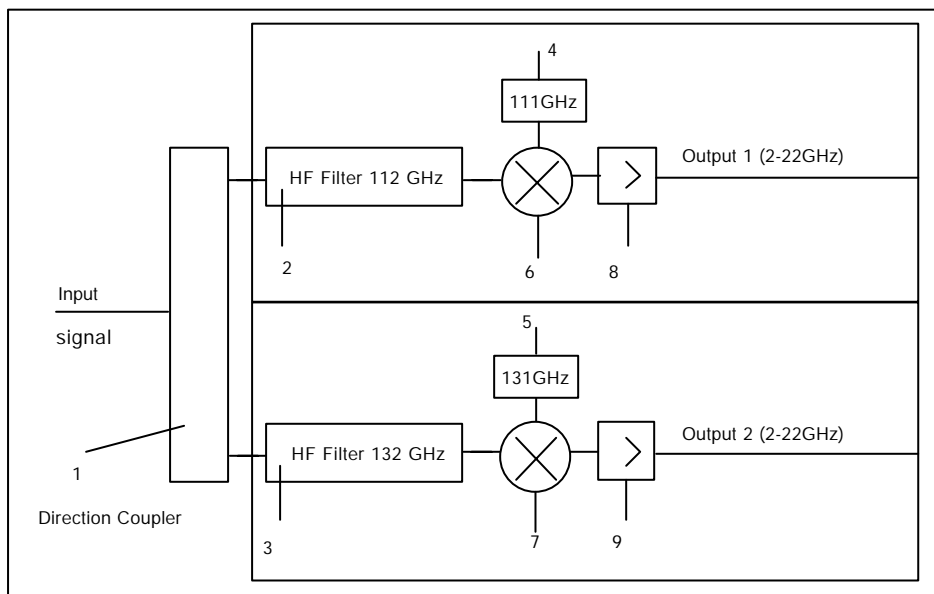

Fig. 7. Block-scheme of the RF Block.

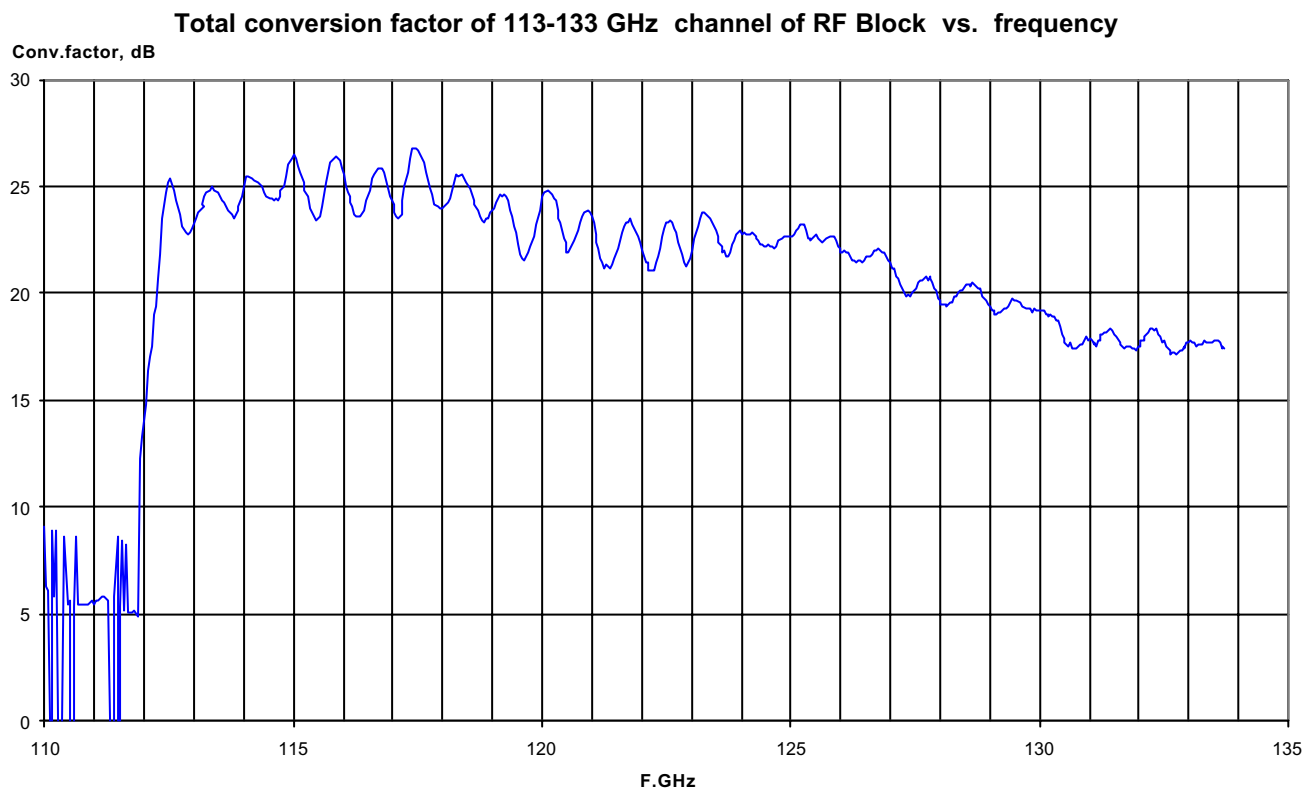

Fig. 8. Total conversion factor of the 113-133 GHz Down Converter vs frequency.

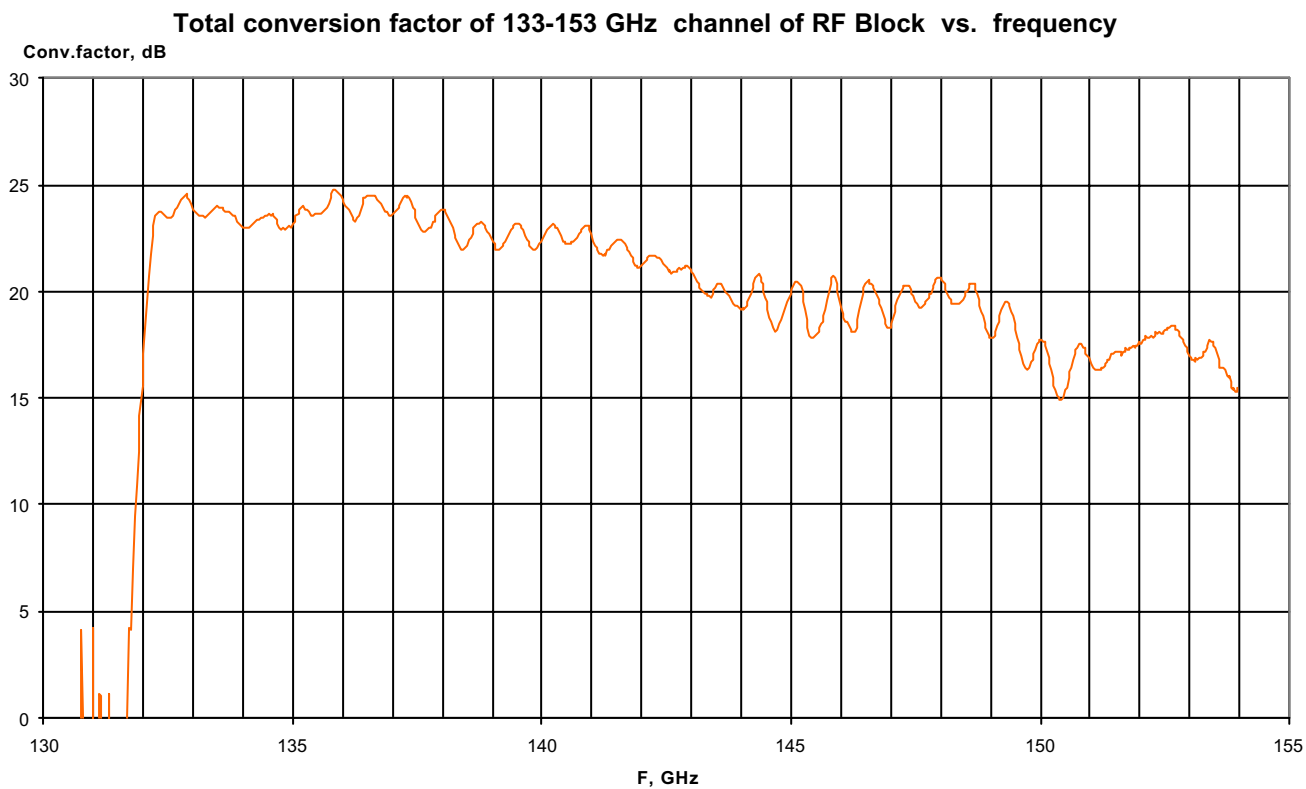

Fig. 9. Total conversion factor of the 133-153 GHz Down Converter vs frequency.

3.2 IF Blocks of the Radiometer

Two 16 channel IF Blocks (Fig. 10) are used in the Radiometer to obtain the 0...+10V output signal proportional to the input power.



Fig. 10. Outward appearance of the IF Block.

Central frequency, f_c , and the bandwidth, Δf , of individual channels of IF Blocks are presented in Tables 1 and 2 for both the Blocks respectively. Distribution of IF Block 2 channels over frequency is organized so that to take into account a need to avoid applying powerful gyrotron 140 GHz heating emission to one of the IF Block channels.

Table 1 (IF Block 1)

Channel number	Central frequency, f_c , GHz	Frequency band width at level -20dB , Δf , GHz
16	21,2	1,20
15	19,8	1,20
14	18,4	1,20
13	17,0	1,10
12	15,7	1,10
11	14,4	1,10
10	13,1	1,10
9	11,8	1,00
8	10,6	1,00
7	9,4	1,00
6	8,2	1,00
5	7,0	0,90
4	5,8	0,90
3	4,8	0,90
2	3,7	0,90
1	2,6	0,90

Table 2 (IF Block 2)

Channel number	Central frequency, f_c , GHz	Frequency band pass at level -20dB , Δf , GHz
16	21,4	1,20
15	20,0	1,20
14	18,7	1,20
13	17,4	1,10
12	16,1	1,10
11	14,8	1,10
10	13,6	1,10
9	12,4	1,00
8	11,2	1,00
7	10,0	1,00
6	8,0	1,00
5	6,8	0,90
4	5,8	0,90
3	4,7	0,90
2	3,6	0,90
1	2,6	0,90

Functional scheme of the IF Blocks is shown below.

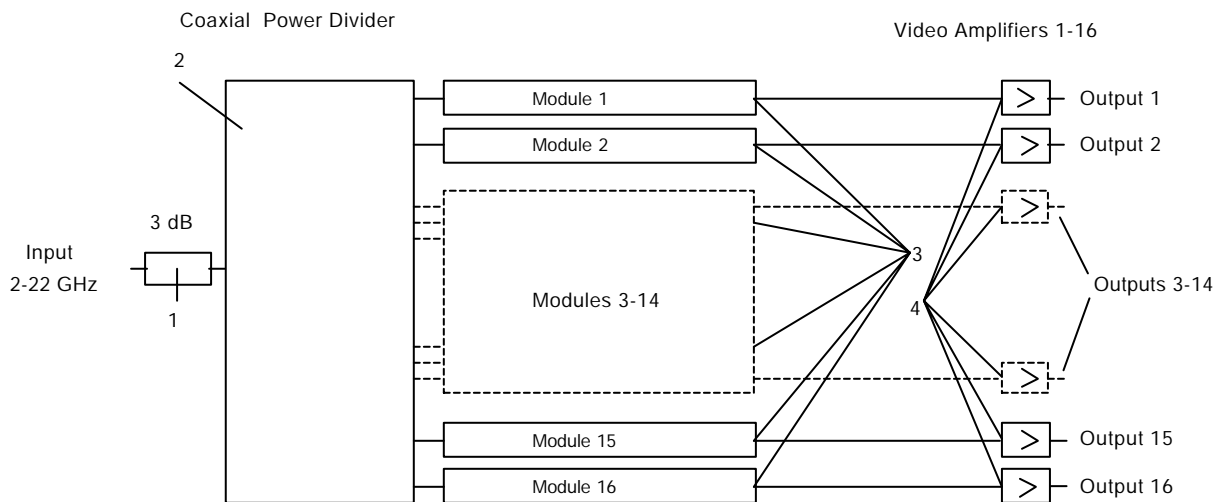

Fig. 11. Block-scheme of the IF Block.

Input 3-dB attenuator (1, Fig. 11) is used for impedance matching Coaxial Power Divider (2, Fig. 11), coaxial cable and the preceding RF Block.

Coaxial Power Divider splits the signal into 16 separate channels, which parameters are listed in the Tables 1 and 2, by means of 16 bandpass filters inside it.

After the Coaxial Divider the signals are applied, in each of the IF Blocks, to 16 Modules (3, Fig. 11) where the second frequency conversion, rectification and

preamplification of the videosignals are carried out. All the Modules are constructed following the same scheme, which is depicted in Fig. 12.

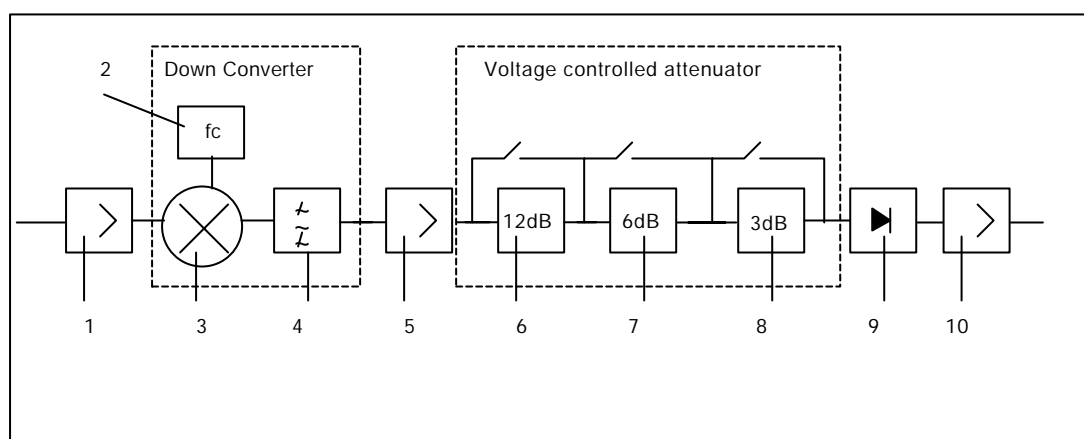

Fig. 12. Module of the IF Block.

Just at the entrance of the Module the signal is amplified with a bandpass amplifier (1, Fig. 12). Then the second frequency conversion is occurred that transforms the input signals with the frequency band of 2÷22 GHz into output signals with frequencies within a range from 0 to about 1 GHz. Balanced mixer (3, Fig. 12), local oscillator (2, Fig. 12) and low frequency bandpass filter (4, Fig. 12) are assembled into a double side band Down Converter unit. The local oscillator frequencies, f_c , are listed in the 2nd columns of the Tables 1 and 2; the filter bandwidths, Δf , can be found in the 3rd columns.

Then the signal passes through another amplifier (5, Fig. 12) with gain factor of 40÷50 dB depending on channel.

Detectors (9, Fig. 12) rectify the entering signals transforming them into output videosignals. Conversion factor of the detectors varies around 50 mV/mW in different channels being linear vs the input power if the latter does not exceed 1 mW. Upper frequency limit of the detectors is not less than 10 MHz.

Voltage controlled attenuators are provided in every channel to keep the power entering the detector below 1 mW thus ensuring the detector linearity. Each the attenuator consists, in turn, of three single attenuators, 3 dB, 6 dB and 12 dB respectively (6, 7 and 8, Fig. 12). This allows changing the attenuation from 0 to 21 dB with 3 dB step.

With the input power level and the conversion factor of the detectors mentioned above, the output signal does not exceed 50 mV. This is why two cascade Video amplifiers are provided in the Radiometer, the first cascade being built in the Modules as preamplifier (10, Fig. 12). It raises ten-fold the output voltage.

The powerful terminal Video amplifiers (4, Fig. 11) are constructed separately outside the Modules in special metal cases. They produce output 0...+10 V signals with frequencies within 0.01 Hz to 1 MHz band.

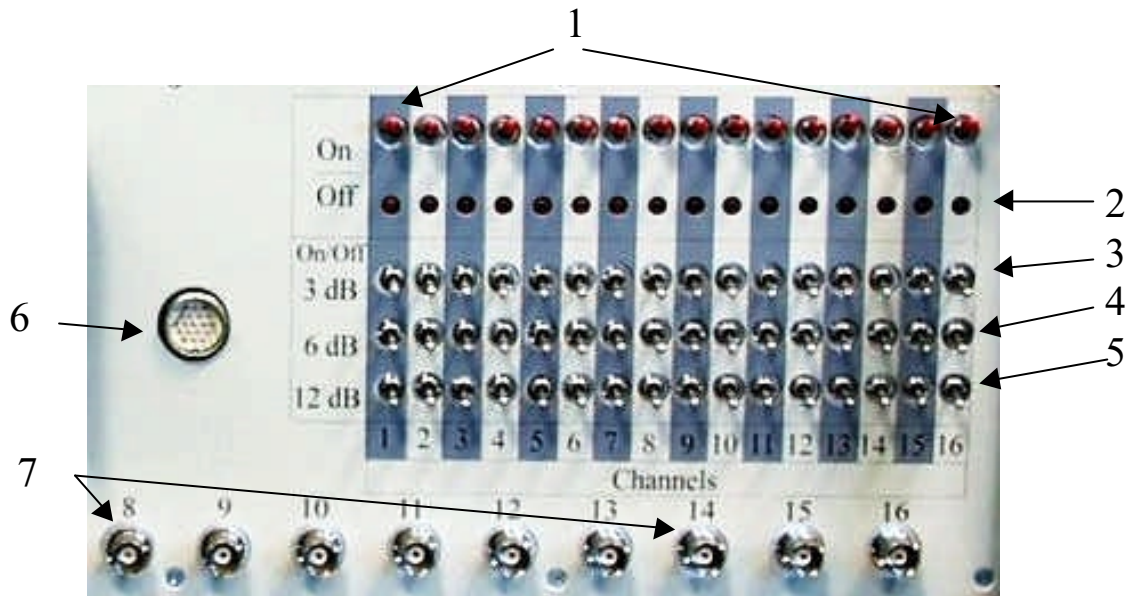

Fig. 13. Front panel of the IF Block.

Fig. 13 represents photo of the IF Block Front Panel. One can see that each of 16 channels has the same set of controls: power supply toggle On/Off (1, Fig. 13; upward position = On), power supply light indicator (2, Fig. 13; lit when the power is On), three toggles for 3 dB, 6 dB and 12 dB attenuators (respectively 3, 4 and 5, Fig. 13; upward position = On). Besides, a socket (6, Fig.13) for connection of the IF Block to the Power Supply Unit by means of a special stranded cable delivered with the Radiometer, and BNC connectors (7, Fig. 13; only a part of the Front Panel is displayed on the photo) for connecting the Radiometer outputs to an external data acquisition system are placed on the Front Panel.

3.3 IF Power Supply Units.

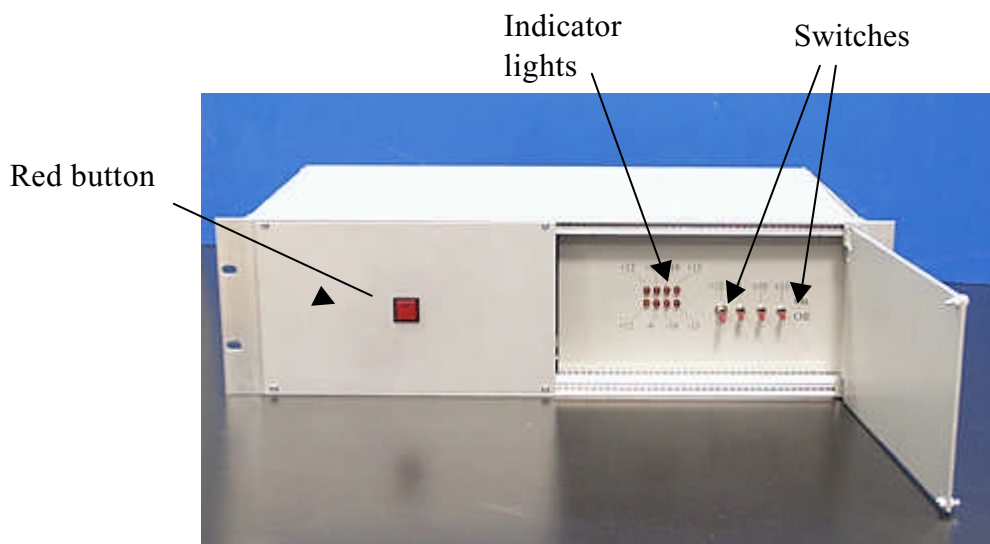

Fig. 14. Outward appearance of IF Power Supply Unit.

Each of two Power Supply Units feeds one of the IF Blocks individually with DC current. The Supply Unit and the IF Block are connected, as it was mentioned above, with a special cable included into the delivery kit. The IF Power Supply Unit appearance is shown in Fig. 14.