

3 Antenas str. LV-1004 Riga Latvia
Phone : +371-7-065100
Fax : +371-7-860022
Mm-wave Division In St.Petersburg, Russia
TEL: +7-812-325-58-58 (ext. 282)
FAX: +7-812-325-58-56 or +7-512-85-01674
Att. D.Korneev

95.0 GHz Transmit-Receive Module for EPR Spectrometer

Operation Manual



St. Petersburg, Russia

(2nd edition. 10.07.98)



MICROWAVE BRIDGE FOR W-BAND EPR SPECTROMETER

Applications

The high-frequency bridge represents a multifunctional W-band transmitter-receiver module (TRM) designed specifically for an EPR spectrometer operation. The TRM has Transmitter to form a probing signal at the center frequency of 95.0 GHz with a power of 80 mW as well as the high-sensitive Receiver with double frequency conversion for an EPR signal detection.

Being capable of either pulsed or CW operation, the system can be operated in several configurations. If integrated into measuring equipment the TRM can be employed in scientific research.

System Description and Functional Characteristics

A simplified functional block diagram of the TRM is shown in figure 1. The system consists of several main blocks: Transmitter, Receiver with double frequency conversion and the master oscillator (STAMO).

The STAMO produces coherent centimeter-wave driving signals (at about 7 GHz). IMPATT Active Frequency Multipliers (AFM) with multiplication factor 13 for W-band are used to transfer driving signals into millimeter wave frequency range. The transfer is realized in Transmitter channels and Receiver Local Oscillator 1 without a significant phase noise degradation. The TRM can be operated in an External Synthesizer configuration to attain the best frequency stability and possibility of frequency adjustment.

Transmitter signal AM and four-level phase-shift keying (4PSK) are provided by means of High-Speed PIN Switches driven by external TTL control pulses. Transmitter channel power gain is achieved using 3-stage CW IMPATT Amplifier.

Receiver is designed on the basis of a double frequency conversion circuit and has two outputs that are 90 out of phase. The Balanced Mixer input of Receiver is protected with a High-Speed PIN Switch against direct application of Transmitter output signal. Another High-Speed PIN Switch is installed at Transmitter output to suppress Transmitter noise during a pause between pulses when the receiver measures EPR signal.

The principle of operation of the system is the following. Reference signal on the frequency 7.168 GHz is divided on two signals on the Directional Coupler. One of the signal is used as a driving signal for Active Frequency Multiplier (AFM), that multiply the frequency in 13 times. It is a signal of the first local oscillator LO1. Another signal is shifted on an up-converter on the frequency of the reference crystal oscillator: $F_0=1820/13$ MHz (140MHz). Shifted frequency is multiplied on another AFM also in 13 times in Transmitter. The difference between launched frequency and frequency of LO1 is equal of the frequency of the reference crystal oscillator multiplied in 13 times (F_0*13). First intermediate frequency of Receiver is 1820 MHz. It is possible to install a band pass filter, that is transparent for frequency of LO1 (F_{lo}) and reject noises on the frequency $F_{lo}+1820$ MHz. That allows to achieve the expected thermal noise of Receiver (based on the mixer specification). Noise of LO1 is negligible in this case. The frequency of a second local oscillator is obtained from the frequency of the reference crystal oscillator F_0 multiplying it in 13 times, so the system operates with zero second IF. I/Q detector is used for measurements of both amplitude and phase of the received signal.

STAMO

As mentioned above, the STAMO provides the coherent centimeter-wave driving signals for both Transmitter and Receiver and operates in two configurations.

1. Internal Stabilized Oscillator Configuration. In this configuration, the TRM operates at a constant frequency of 95.0 GHz. The system output frequency stability is determined by the stability of a Transistor Oscillator at 7.168 GHz stabilized with a high-Q Dielectric Resonator.

2. External Synthesizer Configuration. In this configuration, the reference frequency signal (7.1680.004) GHz is sampled from an External Synthesizer. The operating output frequency in the range of (95.00.05) GHz and output frequency stability are determined by signal parameters of the External Synthesizer.

As one can see on figure 1, the STAMO forms the following signals:

The signal for driving Transmitter.

The center frequency is 7.308 GHz.

The signal for driving Receiver LO1.

The center frequency is 7.168 GHz.

The signal for driving Receiver LO2.

The center frequency is 1.82 GHz.

The signal for testing Transmitter reference frequency.

An interconnection scheme of the STAMO is shown in figure 2.

Transmitter

Transmitter channel is a converter-amplifier appliance that enables transferring the STAMO signal at 7.308 GHz into the signal at 95.0 GHz without significant noise phase degradation and amplifying the last one up to 80mW. Efficient frequency conversion is carried out by an IMPATT CW Frequency Multiplier with a multiplication factor x13 and conversion losses no more than 16 dB. 3-stage IMPATT CW Amplifier provides 17 dB gain.

A current-controlled PIN Attenuator with attenuation range 0-40 dB is installed at the output of the Transmitter. AM of Transmitter output is realized by 2-stage High-Speed PIN Switch 1 with isolation of 70 dB and switching time of about 1 ns. Two High-Speed PIN Switches connected in series allows to achieve that value of isolation.

(0-90, 0-180) 4PSK of Transmitter channel output is carried out by means of two High-Speed PIN Two-Level Phase Shifters.

To suppress the noise of amplifying stages during a pause between the pulses High-Speed PIN Switch 2 with suppression no less than 30 dB is included at Transmitter output. The output power no less than 80 mW is supplied to Transmitter output flange.

Both High-Speed PIN Switches No.1 and No.2 are controlled by means of one driver with one triggering input "AM" on the front panel. The total depth of AM of more then 95 dB is provided.

Receiver

Receiver is designed on the basis of a double frequency conversion circuit. The STAMO sends two signals to Receiver: the driving signal for LO1 at 7.168 GHz and one for LO2 at 1.82 GHz. LO1 is IMPATT CW Frequency Multiplier with a multiplication factor 13 that converts 7.168 GHz signal into the 93.18 GHz. AM noise of the Multiplier is suppressed by means of Band-Pass Filter.

First local oscillator LO1 is switched off during the period when Transmitter launches the millimeter wave pulse. It is provided by means of High-Speed PIN Switch No.4 (see Fig.1). It allows to reduce the leak of launched signal on about 60 dB and prevent the saturation of Receiver.

An EPR signal enters the Balanced Mixer signal input through the waveguide input of Receiver. The signal input of the Balanced Mixer is protected with High-Speed PIN Switch No.3. Switch provides 40 dB isolation.

IF signal at 1.82 GHz amplified by a Low-Noise Preamplifier enters to the input of an I&Q Detector. The IF signal bandwidth is no less than 700 MHz. Receiver provides a noise figure no more than 12.0 dB and a power gain of 30 dB with a video frequency bandwidth no less than 350 MHz.

An interconnection scheme of the TRM is shown in figure 3.

Product Design

The product is fabricated as a stand-alone unit with dimensions 470x300x120 mm³. Transmitter waveguide output and Receiver waveguide input are situated on the rear panel of the device. Input/output waveguides are WR-10. Flanges are UG-387/U.

All controls are allocated on the front panel (see fig.4) of the device as well as the voltage supply connector. The microwave coaxial connectors OSM (SMA) Jack are utilized for the application of control signals

EPR SIGNAL OUTPUT 1 - first output of I/Q detector.

EPR SIGNAL OUTPUT 2 - second output of I/Q detector.

T PS ADJ - the manual adjustment of phase of signal transmitted.

RF TEST - (the left side of the panel) a part of the signal applied to Transmitter at about 7.308 GHz. Used only for test and control purposes.

EXT-INT - the operating configuration switch. "EXT" position corresponds to the External Synthesizer configuration, "INT" position corresponds to the Internal Stabilized Oscillator configuration.

RF EXT IN - input for the signal of External Frequency Synthesizer at (7.1680.004) GHz.

TST ON - switch of thermostat system for the Transistor DRO at 7.168GHz.

REC CONT TTL GATE - Receiver open/close control connector.

TRANS CONT - a series of Transmitter control connectors:

AM TTL TRIG - AM triggering input (TTL).

2PSK TTL TRIG (0-180) - (0-180) 2PSK triggering input (TTL).

2PSK TTL TRIG (0-90) - (0-90) 2PSK triggering input (TTL).

ATT CONTROL DC - the connector for Transmitter output to be attenuated by control DC.
OPER MODE
PULSE-CW - the TRM operating mode switch. The "PULSE" position corresponds to the pulsed mode. "CW" position corresponds to the CW mode of operation.
MEASUR-TUNING - the operating submode switch for switching between tuning mode and measuring one.

Pulsed mode

In the pulsed mode, the TRM supplies AM modulated millimeter wave signal. The microwave pulse length and period of pulse repetition are determined by the parameters of the TTL control pulses supplied to the AM TTL TRIG input connector.

Opening and closing of Receiver is provided by TTL control pulses supplied to the TTL GATE input connector. Transmitter AM and Receiver on/off switching are carried out by means of four High-Speed PIN Switches (see block diagram, figure 1).

2-stage High-Speed PIN Switch 1 provides AM of Transmitter output with isolation of 70 dB.

High-Speed PIN Switch 2 with isolation of 30 dB introduces an additional depth of modulation of Transmitter output and suppresses the CW IMPATT Amplifier noise of the transmit channel during a pause between microwave power pulses as well.

High-Speed PIN Switch 4 turns off LO1 power on the period while Transmitter radiates the power. The switching off the LO1 power prevents the saturation of Receiver and provides linear conditions of operation.

High-Speed PIN Switch 3 with isolation of 40 dB intended to be used to protect Balanced Mixer from microwave pulses of Transmitter.

There is a logic and four drivers in the system which serve the proper order of switching on/off of all High-Speed PIN Switches. Figure 5 shows a switching scheme for the High-Speed PIN Switches as a function of the control signals derived from the External TTL Pulse Oscillator and supplied to the AM TTL TRIG and TTL GATE control connectors.

The "on" Switch state corresponds to the minimum loss performance, while the "off" state corresponds to the maximum isolation performance.

The TTL high ("1") signal supplied to the AM TTL TRIG input connector results in Transmitter channel power being emitted while the TTL low ("0") signal supplied to that causes its power being suppressed.

Receiver is driven by the control signal entering the TTL GATE input connector, the TTL high ("1") signal turning Receiver on and TTL low ("0") signal turning Receiver off. However (as seen in figure 5, version a), when Transmitter channel is emitting microwave power pulses, Receiver is always off irrespective of a signal at the TTL GATE control connector. Receiver is on only for a case of Transmitter power being suppressed when the TTL high signal enters the TTL GATE connector (version c). This prevents the possibility of the Balanced Mixer failure.

While operating in the pulsed mode, it is possible to perform fast 4PSK of Transmitter output. The TTL low or TTL high signal supplied to the 2PSK TTL TRIG (0-180) input connector results in 180 of phase change of Transmitter output. The TTL low or TTL high signal supplied to the 2PSK TTL TRIG (0-90) input connector results in 90 of phase change of Transmitter output.

The output pulse power of Transmitter channel can be attenuated by control current supply to the ATT CONTROL DC input connector. Figure 6 shows the attenuation as a function of a control current.

The pulsed mode has two submodes: the measuring submode and tuning one.

In the measuring submode, High-Speed PIN Switches 1,2,3,4 are switched by the same scheme as shown in figure 5. Turning on Receiver is delayed on 16, 24 or 32 ns relative to the end of Transmitter pulse.

The tuning submode is employed for the EPR spectrometer resonator being tuned. In this submode, isolation between Transmitter and Receiver is intentionally reduced, which is achieved by switching High-Speed PIN Switch 4 to the "on" state, and as a result Receiver LO1 power enters the Balanced Mixer even though for a case of Transmitter pulses being emitted.

CW Mode

In the CW mode, High-Speed PIN Switches 1,2,3,4 are in the "on" state, which corresponds to the minimum loss performance. Because of this, Transmitter emits a CW signal with an output power of 80 mW. Receiver is fully opened and Receiver protection alarm system is switched off.

A t t e n t i o n. Since Receiver protection alarm system is turned off in this mode it is not allowed to supply Transmitter power output above 1 mW to the Balanced Mixer input so as to avoid its failure.

Operating Order

1. Supply the TRM with voltages by the power cable in accordance with a table of supply voltages.

A t t e n t i o n! The voltage of +12 V is allowed to be applied to the supply voltage connector only after supplying the voltage of minus 12 V. Turning the supply voltages off should be performed in a reverse order.

2. While operating in the Internal Stabilized Oscillator configuration, put the INT-EXT switch (the right side of the panel) into the "INT" position (with the red indicating lamp lighted up).

Testing of Transmitter reference frequency of 7308 MHz can be carried out by connecting a frequency meter to the RF TEST connector. The testing signal power at the RF TEST connector is about 1 mW.

3. While operating in the External Synthesizer configuration, supply the External Synthesizer signal to the RF EXT IN connector. The signal frequency is within the range (7164-7172) MHz. The Synthesizer power output 5-10 mW should be provided.

Put the INT-EXT switch (the right side of the panel) into the "EXT" position.

4. While operating in the pulsed mode, put the PULSE-CW switch into the "PULSE" position.



While tuning the EPR spectrometer resonator, put the MEASUR-TUNING switch into the "TUNING" position.

While measuring, put the switch into the "MEASUR" position.

The control signals should be supplied to the REC CONT and TRANS CONT connectors in accordance with the section: Pulsed Mode.

Transmitter channel phase adjustment should be carried out by turning the T PS ADJ knob.

After double frequency conversion, the EPR signal detected by Receiver enters the EPR SIGNAL OUTPUT 1 and EPR SIGNAL OUTPUT 2 connectors. The output signals at these connectors have 90 of phase shift with respect to each other.

5. While operating in the CW mode, put the PULSE-CW switch into the "CW" position and the MEASUR-TUNING switch into the "MEASUR" one.

Transmitter channel phase adjustment should be carried out by turning the T PS ADJ knob.

After double frequency conversion, the EPR signal detected by Receiver enters the EPR SIGNAL OUTPUT 1 and EPR SIGNAL OUTPUT 2 connectors. The outputs at these connectors have 90 of phase shift with respect to each other.

A t t e n t i o n. In the CW mode, it is not allowed to supply Transmitter power output above 1 mW to Receiver input so as to avoid its failure.

Duty conditions

1. The product is to be incorporated in the EPR spectrometer and employed for in-door operation under standard climatic conditions free of mechanical perturbations:

Ambient Temperature, C25±10

Relative Humidity, %70

2. **A t t e n t i o n!** While transporting, storing, assembling, and operating, it is necessary to preclude entering any particles (especially magnetic ones) into the waveguide channel so as to avoid the product failure.

3. Warm-up time after switching on is 1 hour (max).

4. Continuous duty time is 8 hours.

Specifications

1. TRANSMITTER

*PULSE MODE**Internal Stabilized Oscillator Configuration*

Characteristic, units	Target	Measured Value
1. Output frequency fixed, GHz	95.0	95.000
1a. Injection Locking Bandwidth, MHz	100	+/-130
2. Output frequency instability, kHz/h	-	< 100*
3. Output spectral linewidth at the level -3dB, kHz	-	< 1
4. Output power, mW	80	92
5. Output power attenuation range, dB	40	70
6. Microwave pulse duration at the level -3dB, ns		
min	5	5
max	continuous	continuous
7. Pause duration between microwave pulses, ns		
min	10	10
max	continuous	continuous
8. Microwave power switching time at the level 0.1/0.9, ns	2	1
9. Microwave power suppression during a pause between pulses, dB	-	95
10. Switching time up to maximum suppression level, ns	-	8
11. Accuracy of 180 deg phase shift keying of 2PSK for 95.0 GHz frequency, deg	-	< 1
12. Accuracy of 90 deg phase shift keying of 2PSK for 95.0 GHz frequency, deg	-	< 5
13. Switching time for 2PSK, ns	5	5

14. Output parasite AM level for 2PSK, dB	-	< 0.2
---	---	-------

* After 2 hours heating

2. TRANSMITTER

PULSE MODE

External Synthesizer Configuration

Characteristic, units	Measured Value				
1. Output frequency, GHz	94.870	94.935	95.000	95.065	95.130
2. Output power, mW	93	93	92	91	89
3. Microwave power suppression during a pause between pulses, dB	95	95	95	95	95
6. Accuracy of 180 deg phase shift keying for 2PSK, deg	3	2	<1	1	2
7. Output parasite AM level for 2PSK, dB	< 0.2	< 0.2	< 0.2	< 0.2	< 0.2

3. TRANSMITTER

CW MODE

Characteristic, units	Measured Value				
1. Output frequency, GHz	94.870	94.935	95.000	95.065	95.130
2. Output power, mW	93	93	92	91	89

4. RECEIVER

4.1 Internal Stabilized Oscillator or External Synthesizer Configurations

Characteristic, units	Measured Value				
1. Input signal frequency, GHz	94.870	94.935	95.000	95.065	95.130
2. Noise figure, dB	10.6	10.5	10.5	10.4	10.4
3. Power gain, dB	37.3	37.5	37.5	37.6	37.7
4. IF bandwidth, MHz	700				
5. 3 dB video bandwidth, MHz	350				

4.2 Measurements using external mm-wave noise source and IF noise meter

Characteristic, units	Measured Value		
1. IF frequency, GHz	1.452	1.82	2.187
2. Noise figure, dB	11.4	10.5	11.2

3. Power gain, dB	36.5	37.5	33.1
-------------------	------	------	------

5. TRANSMITTER - RECEIVER

- Total phase drift - 5deg/15 minutes.
- Manual signal phase adjustment
for transmitter - more than 360 deg (540 deg).
- Discrete values of Receiver protection time after every pulse of Transmitter for marks 1, 2, 3 amount to 14 ns, 17 ns, 20 ns, respectively, the value of 14 ns being the minimum achievable interlocking time.

6. SUPPLY VOLTAGE AND DRAIN CURRENT PARAMETERS

Supply Voltage	Drain Current
U1 = +27V ^{+1V} -0.5V	I1 = 1.2±0.8 A
U2 = +12V ± 0.5V	I2 = 2.0 A
U3 = -12V ± 0.5V	I3 = 0.6 A

6. THE TTL CONTROL PULSE PARAMETERS

TTL high ("1")	(+2.4 - +4) V
TTL low ("0")	(0 - +0.4) V
Switching time 0.1/0.9 x V	no more than 1 ns
Load resistance	50 ohm

7. REFERENCE DATA

- The output power at the connector RF TEST is about 1.5 mW.
- The input power that should be supplied by External Synthesizer to the connector RF EXT IN is (5-10) mW.
- The output signal frequency of Transmitter is related to the input signal frequency of the External Synthesizer by the following relationship:

$$F_{out} \text{ (MHz)} = [F_{input\ svn} \text{ (MHz)} + 140] \times 13.$$

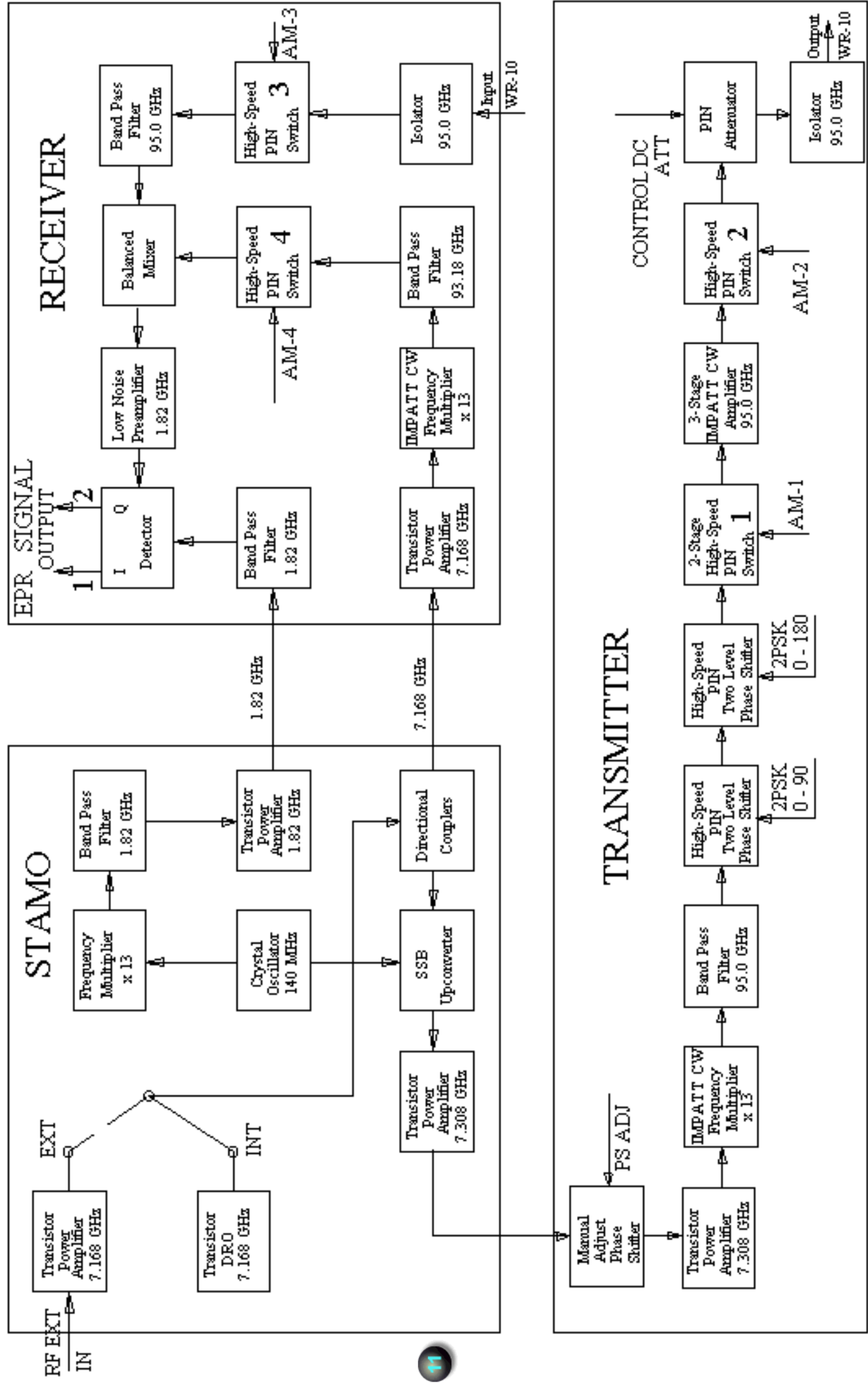

Fig. 1. Functional Block Diagram of 95.0 GHz Coherent Transmitter-Receiver Module

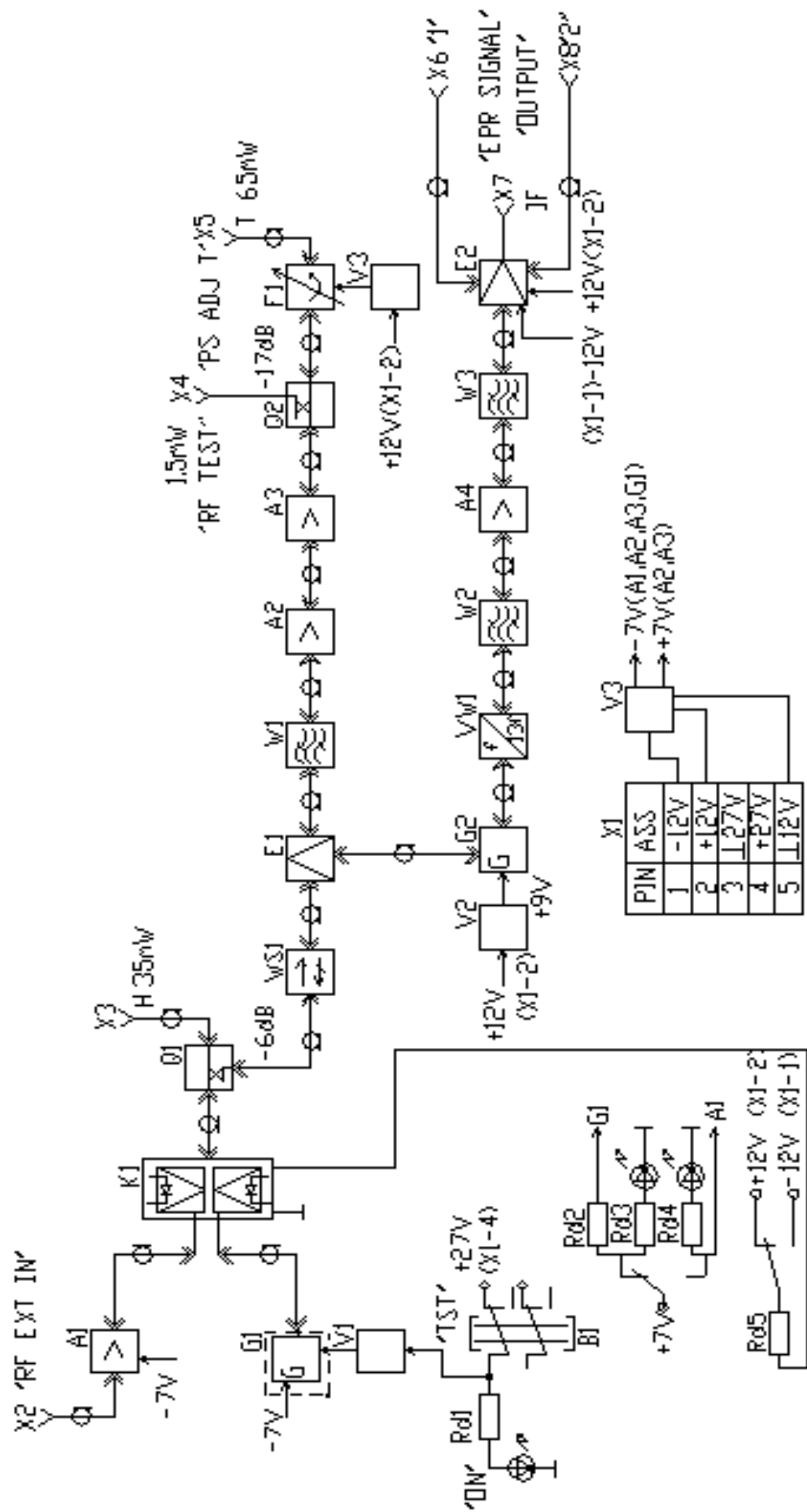

Fig. 2 Interconnection scheme of STAMO

Component Designation	Component Name
G1	Transistor DRO
G2	Reference Crystal Oscillator
A1÷A4	Transistor Power Amplifier
W1÷W3	IF Band Pass Filter
Q1	Microstrip Directional Coupler
Q2	Microstrip Power Divider
F1	Manual Adjust Coaxial Phase Shifter
E1	SSB Upconverter
E2	Detector
WV1	Frequency Multiplier ×13
V1	Thermostat Control Circuit
V2, V3	Regulation Circuit
B1	Switch
K1	Coaxial Switch
X1	Voltage Supply Connector
X2÷X8	Connector OSM (SMA)

List of Component to Interconnection Scheme of the STAMO (fig. 2).

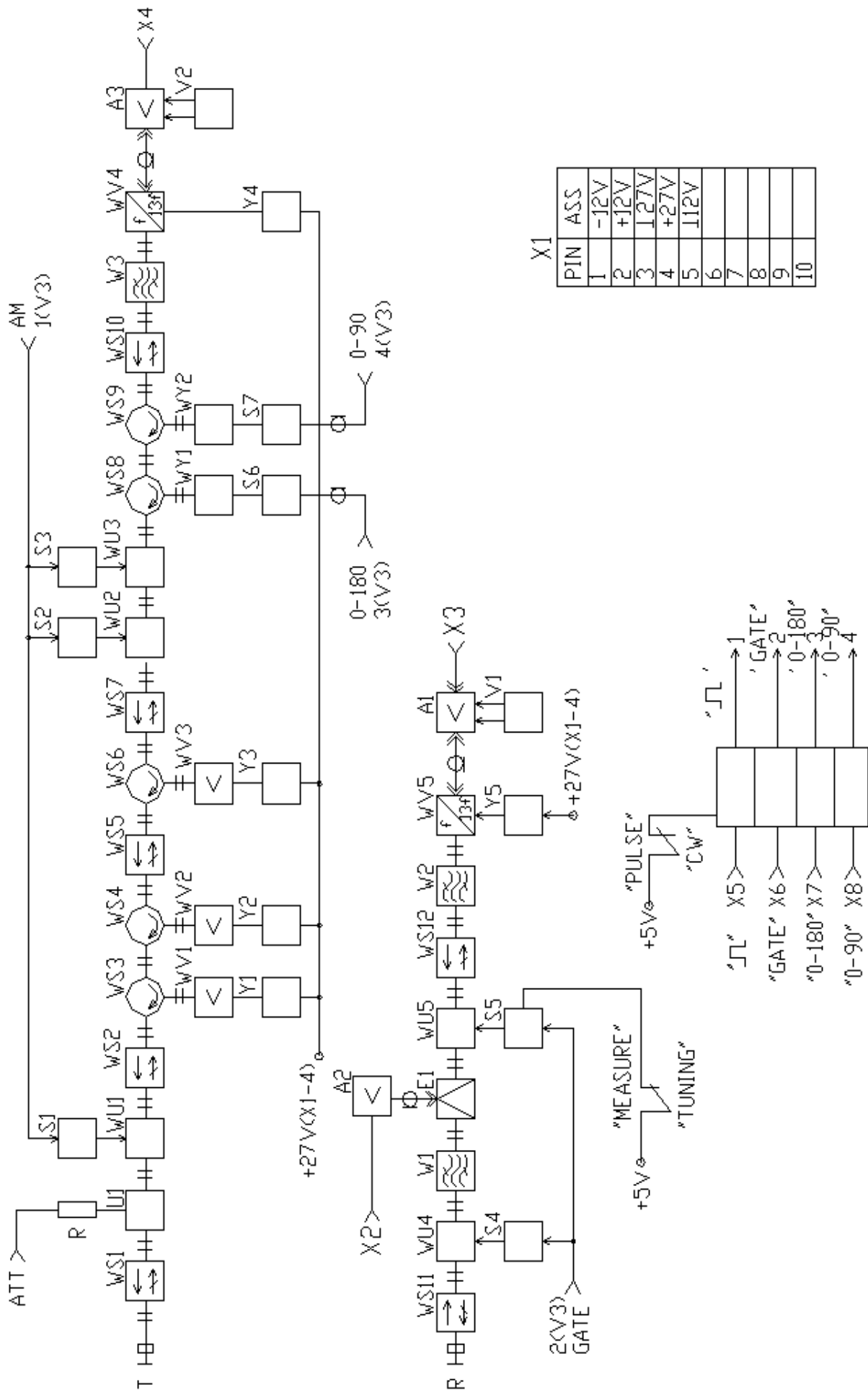

Fig.3 Interconnection scheme of the Transmitter-Receiver Module

Component Designation	Component Name
WS1 +WS12	Waveguide Circulator
WV 4+WV 5	IMPATT CW Frequency Multiplier
WV1+WV3	IMPATT CW Amplifier
WU1+WU5	High-Speed PIN Switch
WY1, WY2	High-Speed PIN Two Level Phase Shifter
U1	PIN Attenuator
S1+S7	Driver
Y1+Y5	Current Regulator
W1+W3	Waveguide Band Pass Filter
E1	Balanced Mixer
A2	Low Noise Preamplifier
A1,A3	Transistor Power Amplifier
V1+V2	Voltage Regulator and Control Circuit
X1	Voltage Supply Connector
X2+X8	Connector OSM (SMA)

List of Component to Interconnection Scheme of the Transmitter-Receiver Module (fig.3).

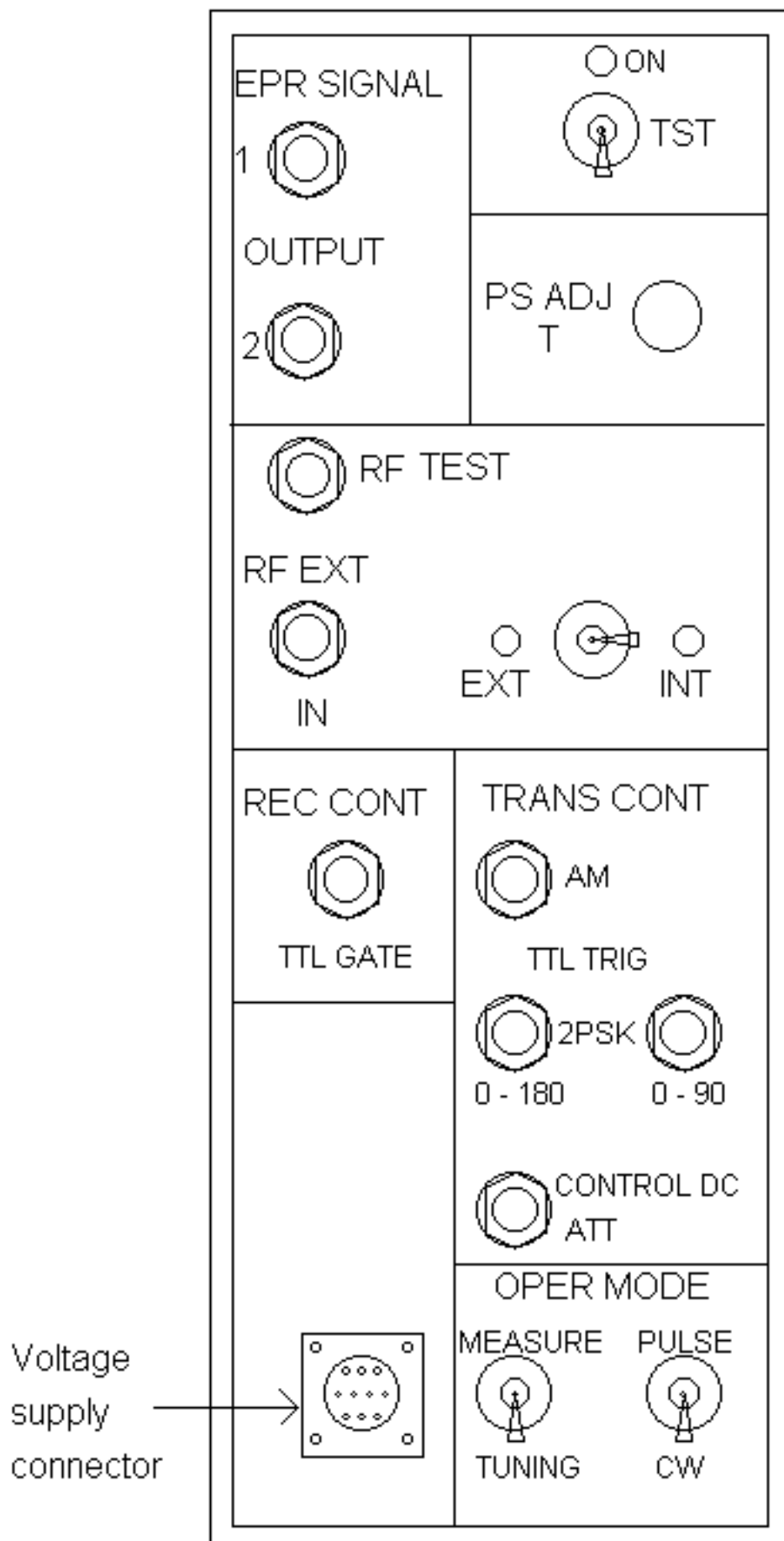

Fig.4. Front Panel

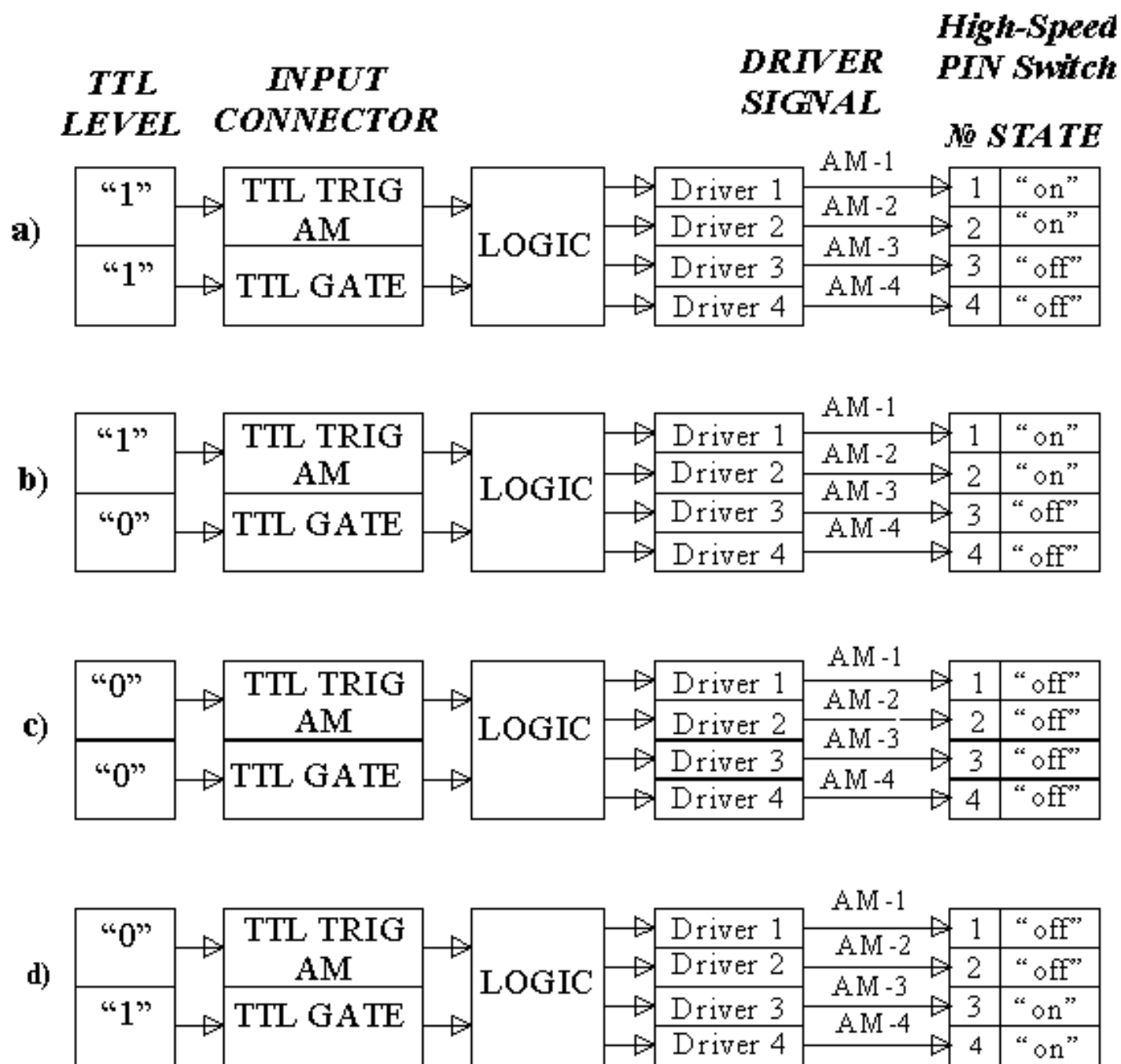

Fig.5. Switching Scheme.