

120-180 GHz Sweeping Heterodyne Radiometer

Introduction

An original version of the Millimeter-wave Sweeping Radiometer (MSR) was developed in 1995 by request of Tokamak Division of Southwestern Institute of Physics, Chengdu, China. On agreement with the purchaser, the device, which by the present was far beyond its lifetime, has been recently restored and modernized. Just after completing the modernization, the renovated version had been tested *in situ* by applying to electron temperature measurements in HT1-M tokamak experimental campaign of September 2000.

The temperature measurements by means of 2nd ECE (Electron Cyclotron Emission) harmonic are the principal domain of the Radiometer application. It should be used for tokamak plasmas at the toroidal magnetic field within 2 to 3 T according to its frequency range.

The fact is taken as the basis of the method that in the magnetized plasma electrons emit electromagnetic energy at electron cyclotron frequencies, its intensity being proportional to the electron temperature if the plasma is the black body for its own emission. Typically, if the latter condition is satisfied experimentally, the electron cyclotron frequencies are less than those of electron plasma oscillations and the plasma turns out to be opaque for the fundamental ECE harmonic. This is why it is the 2nd one that is used for the electron temperature measurements. As there is the toroidal magnetic field gradient in the tokamak plasma, electrons at different points along the major radius of the torus radiate at different frequencies proportional, in turn, to local magnetic fields. So, electron temperature distribution along the major radius (T_e radial profile) can be measured by changing the frequency received by the Radiometer.

Specifications

Frequency range, GHz	120-180
Receiver noise factor, dB above kT_0	less than 20
Relative input dynamic range above the noise level, dB	20
IF bandwidth (single sideband), GHz	1.5
Measurement time at each frequency value, μ s	not less than 50 (can be reduced to 25 μ s if the difference between two adjacent frequency steps is less than 3 GHz)
Output video amplifier integration constant, μ s	less than 1

General arrangement and principles of functioning

Plasma measurements

The equipment supplied provides three different Radiometer configurations. Block diagram of the configuration intended for the plasma measurements is shown on Fig.1 The mm-wave signal from plasma (MMW Input) comes to a voltage controlled Attenuator at the Radiometer input and then passes via a waveguide switch (MMW Switch) to Mixer signal input (SI). A signal from 120-180GHz BWO (Backward Wave Oscillator), that serves as the local oscillator, arrives to another Mixer input (LO). The 3.5GHz bandwidth intermediate frequency signal (IF) passes through two band-pass filters and two band-pass amplifiers, which cut off the higher frequencies resulting in a narrower bandwidth, 0.1 to 1.5 GHz, and then comes to Video Detector. Through Video Amplifier the video signal, proportional to the input power integrated over $1.5\text{GHz} \times 2 = 3\text{GHz}$ bandwidth, goes to Lock-in Detector and further via an analog-to-digital converter (ADC) to digital data acquisition system.

An IBM PC compatible computer performs function of the latter, besides it controls BWO and synchronizes the Lock-in Detector with input signal when calibrating the Radiometer by means of LN Cooled Matched Load (Only the software is supplied by the manufacturer, but not PC itself.)

The local oscillator calibration curves, frequency vs. controlling voltage and power vs. frequency, are shown on Fig.2 and Fig.3 respectively. Scanning BWO within its frequency range, 120 to 180GHz, is realized in a way demonstrated in Fig.4. Stepped controlling voltage is derived from PC through a digital-to-analog converter (DAC) to BWO. Accordingly, a signal with time varying frequency is produced at the BWO output, the frequency settling time for each frequency step being equal to 20-30 μ s whereby the minimum measurement time is defined. The IF (and

video) signals corresponding to the different BWO (and accordingly, to different input) frequencies are related to the different radial positions in the plasma as it has been noted in the Introduction.

Frequency calibration

The frequency calibration is performed for the checking of the frequency step values generated by the local oscillator. Block diagram of the Radiometer configuration intended for the calibration is displayed on Fig.5. Here a calibration signal from a Harmonic Oscillator comes to the waveguide switch and further to the Mixer instead of the plasma one. Being much more powerful than the signal radiated by the plasma, after video detecting it goes directly to ADC and to the data acquisition system with no additional amplification. The Harmonic Oscillator consists of master 6GHz Oscillator and Frequency Multiplier. At the output they produce a signal consisting of 11 harmonic components, 120, 126, ..., 174, 180 GHz. Result of the calibration experiment is represented in Fig.6.

Calibration by means of LN Cooled Load

Calibration of the Radiometer measuring circuit by means of the liquid nitrogen cooled matched load (LNML) is carried out for checking of the long term device stability. The scheme of the calibration experiment is shown on Fig.7. LNML presents a standard black body noise source perfectly stabilized at LN boiling temperature, -195.8°C or 77.4°K. While calibrating, LNML is connected to the Radiometer input, the signal being passed through a voltage controlled Attenuator. The Attenuator is modulated with 1kHz Oscillator, alternately opening and closing the input waveguide. Since the black body heat emission at both room and LN temperatures is extremely weak, the video signal passes through the Video Amplifier and then is accumulated during whole the measurement time with the aid of synchronous detector, which role is performed by the Lock-in Detector controlled with the same 1kHz Oscillator as the Attenuator. The resulting LNML signal is obtained by subtracting the signal at the closed Attenuator, that is noise of the Radiometer itself, from the signal at the opened input waveguide. The lower curve in Fig.8 is the signal at the closed Attenuator, the upper one is the LNML radiation. It can be compared with similar curves obtained during previous experimental campaigns.

Conversion losses and intrinsic noise of the receiver

As it has been mentioned above, in a typical experiment the electron plasma temperature has to be measured at different radial points, i.e. at different frequencies. However, the proportionality coefficient between the input mm-wave power and the output video signal varies with the frequency. The cause is frequency variations of signal conversion losses in the Mixer. Their dependence on frequency is depicted on Fig.9. It allows to deduce the input power from the output video signal.

The receiver noise factor in dB vs frequency is plotted in Fig.10. Together with the lower curve of Fig.8 corrected with the aid of Fig.9 it establishes correspondence between the output signal in Volts and the relative dB scale of the input power. Additionally, the measured power can be corrected for the receiver intrinsic noise for higher accuracy (at lower plasma temperatures).

Experimental results

The Radiometer had been applied to electron temperature measurements in HT1-M tokamak during the experimental campaign of September 2000. Time evolution of the electron temperature (in arbitrary units) measured at different frequency (i.e. radial) points is shown on Fig.11. Fig.12 represents several radial temperature profiles taken for different moments. In the experiments the temperatures measured ranged from tens up to many hundreds of eV, the typical measurement accuracy was 1 to 2 eV.

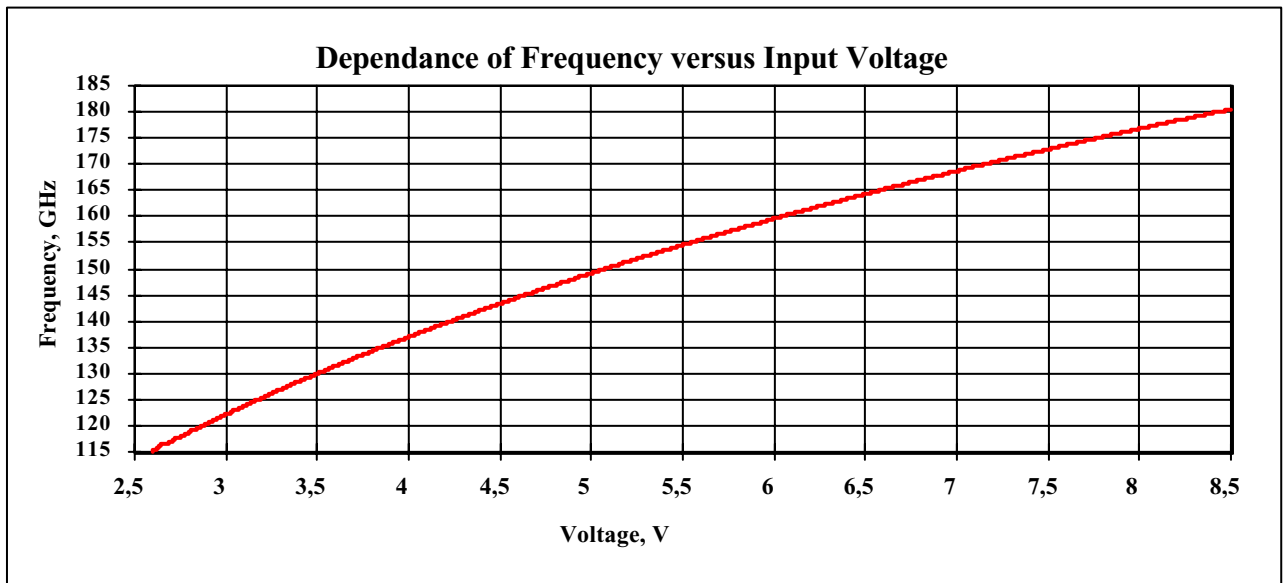
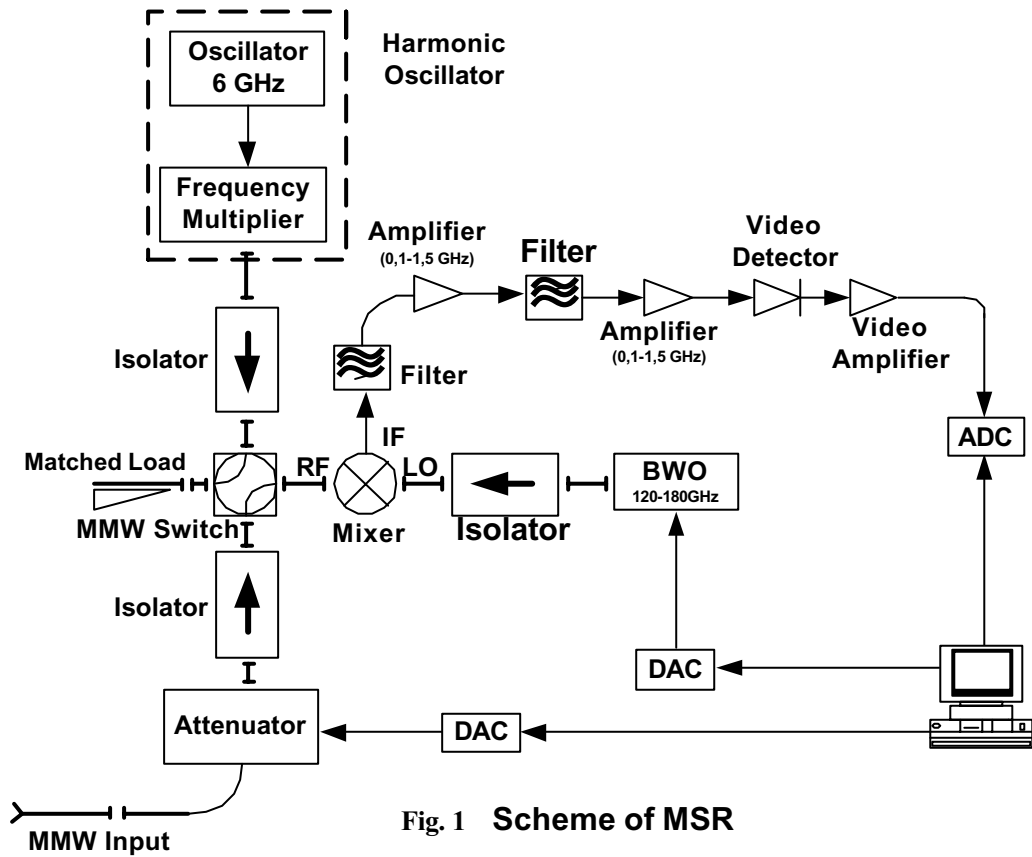
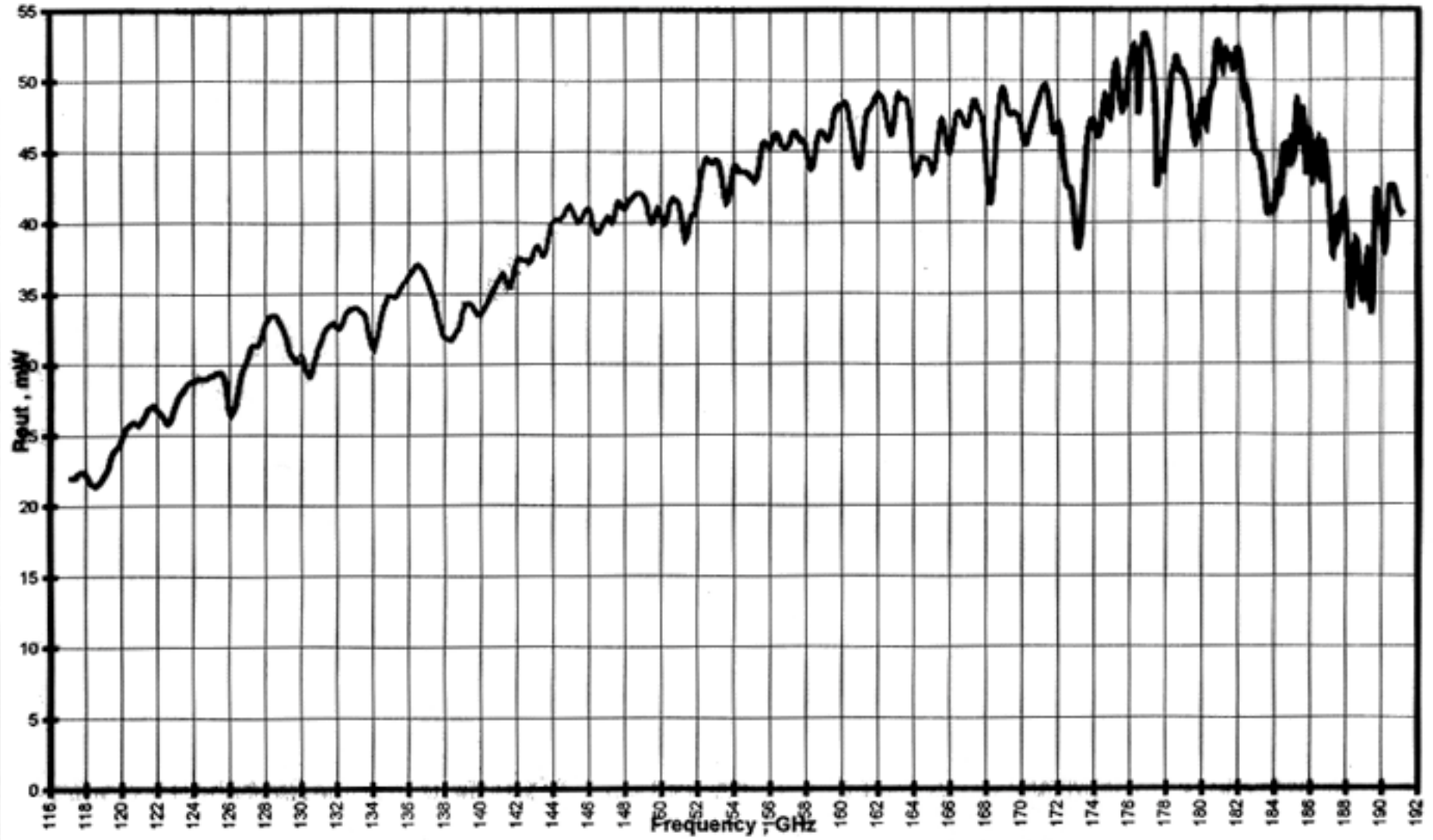

Fig. 2

Output Power vs. frequency

Fig. 3



Principles of Operation

Fig. 4

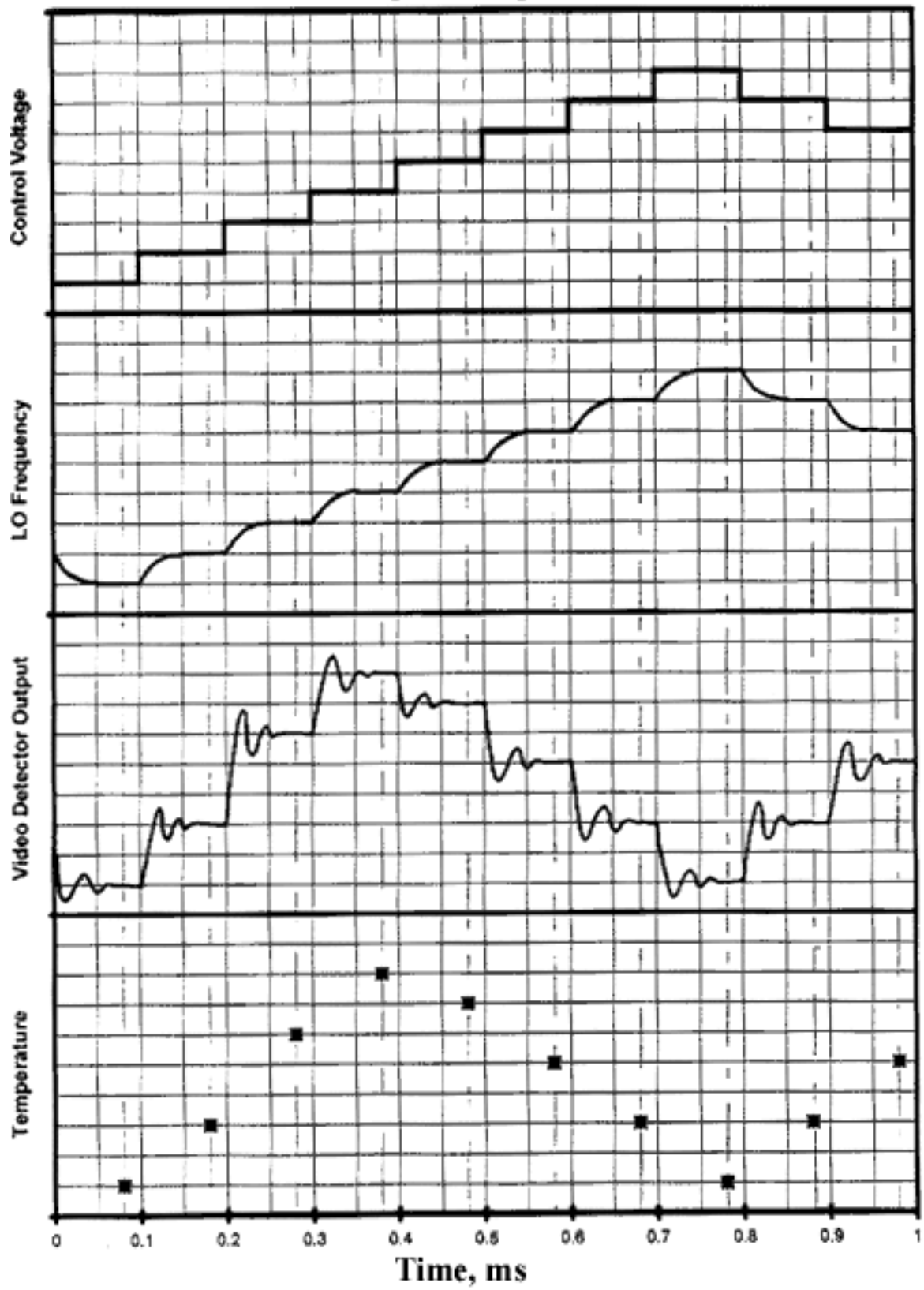

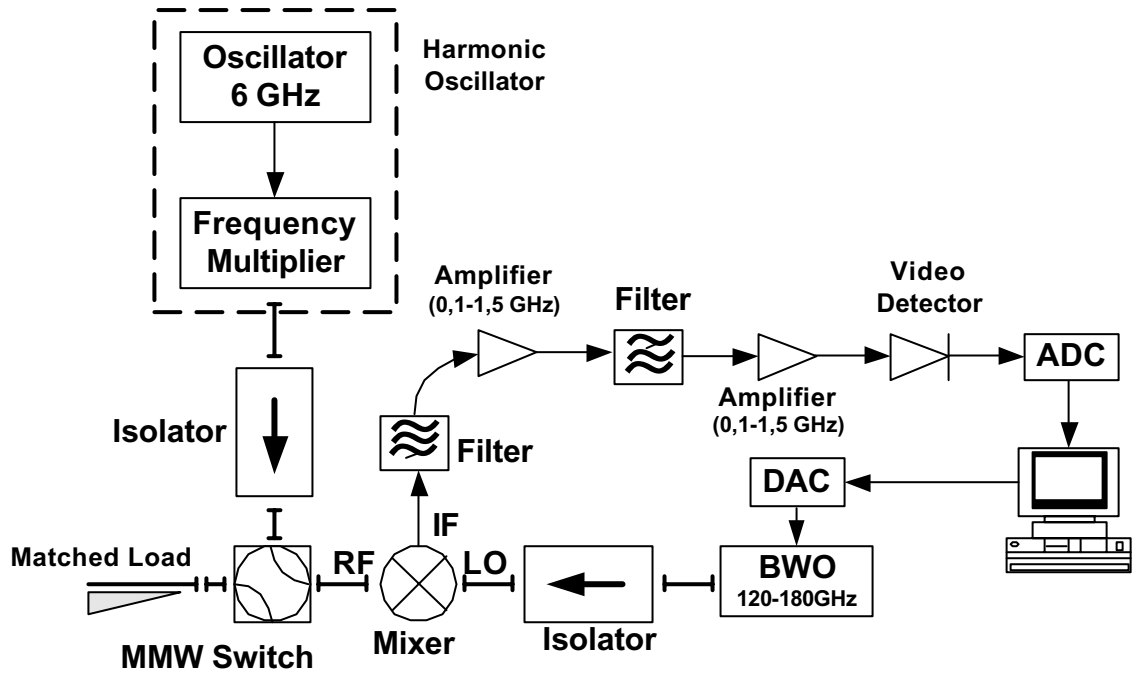
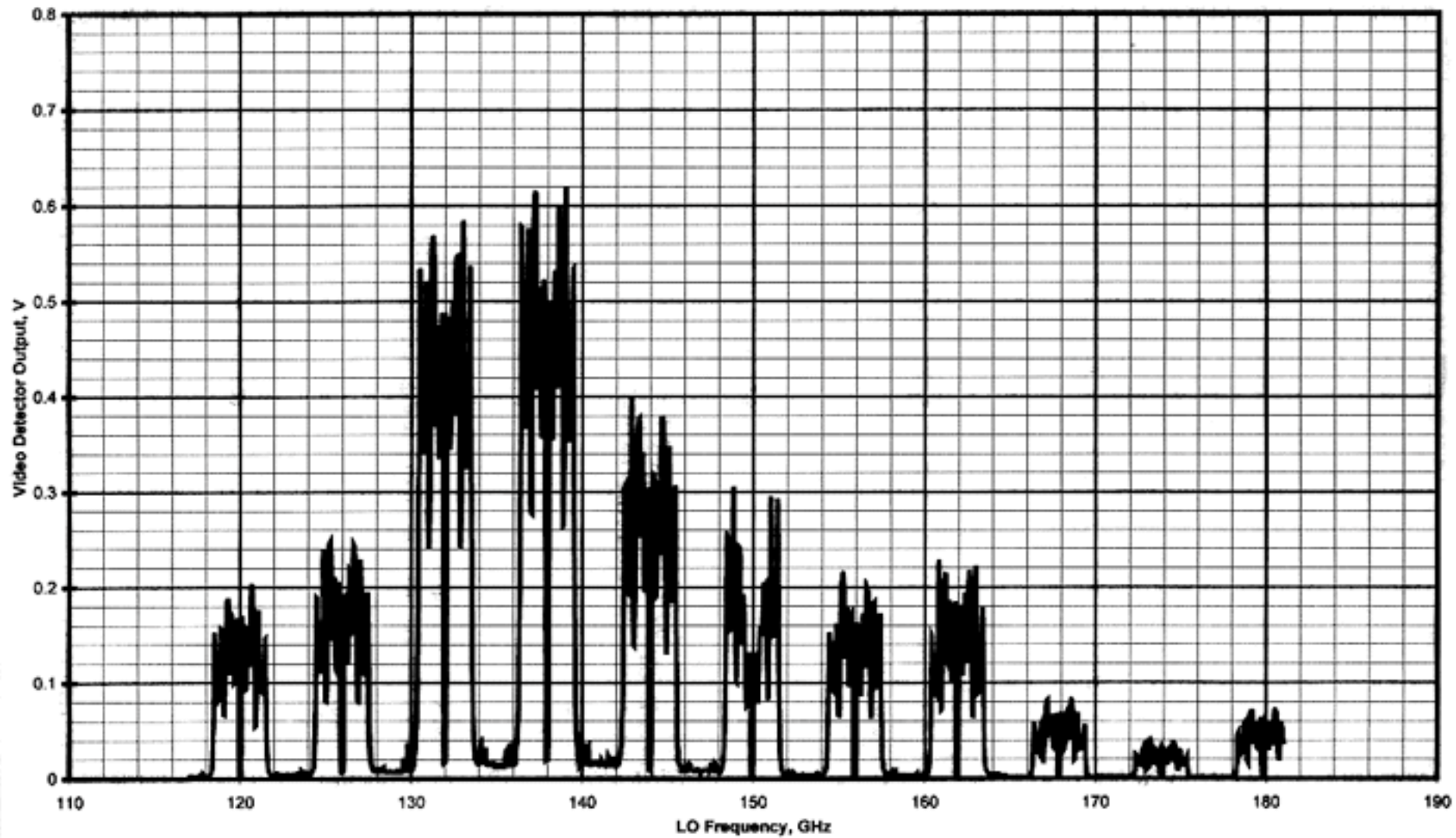

Fig. 5 Calibration by means of Harmonic Oscillator

Harmonic Oscillator

Fig. 6



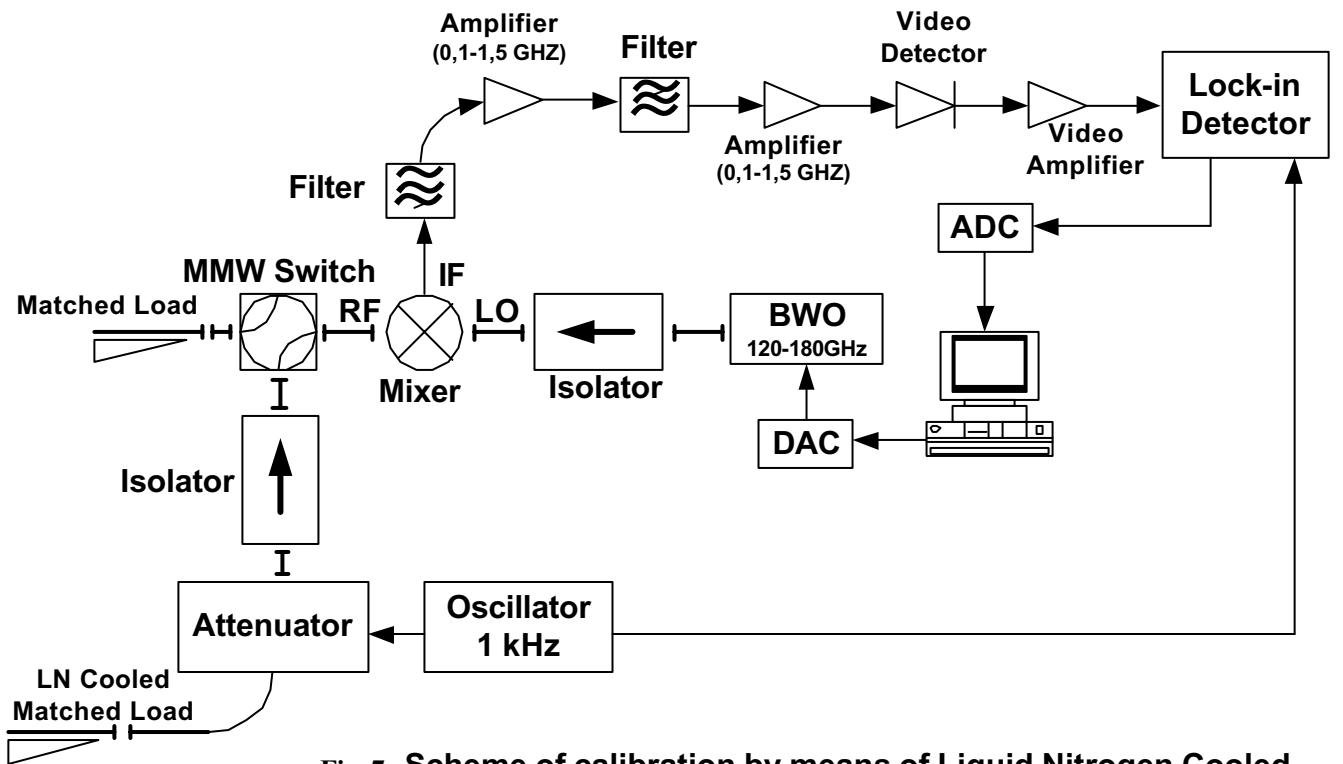
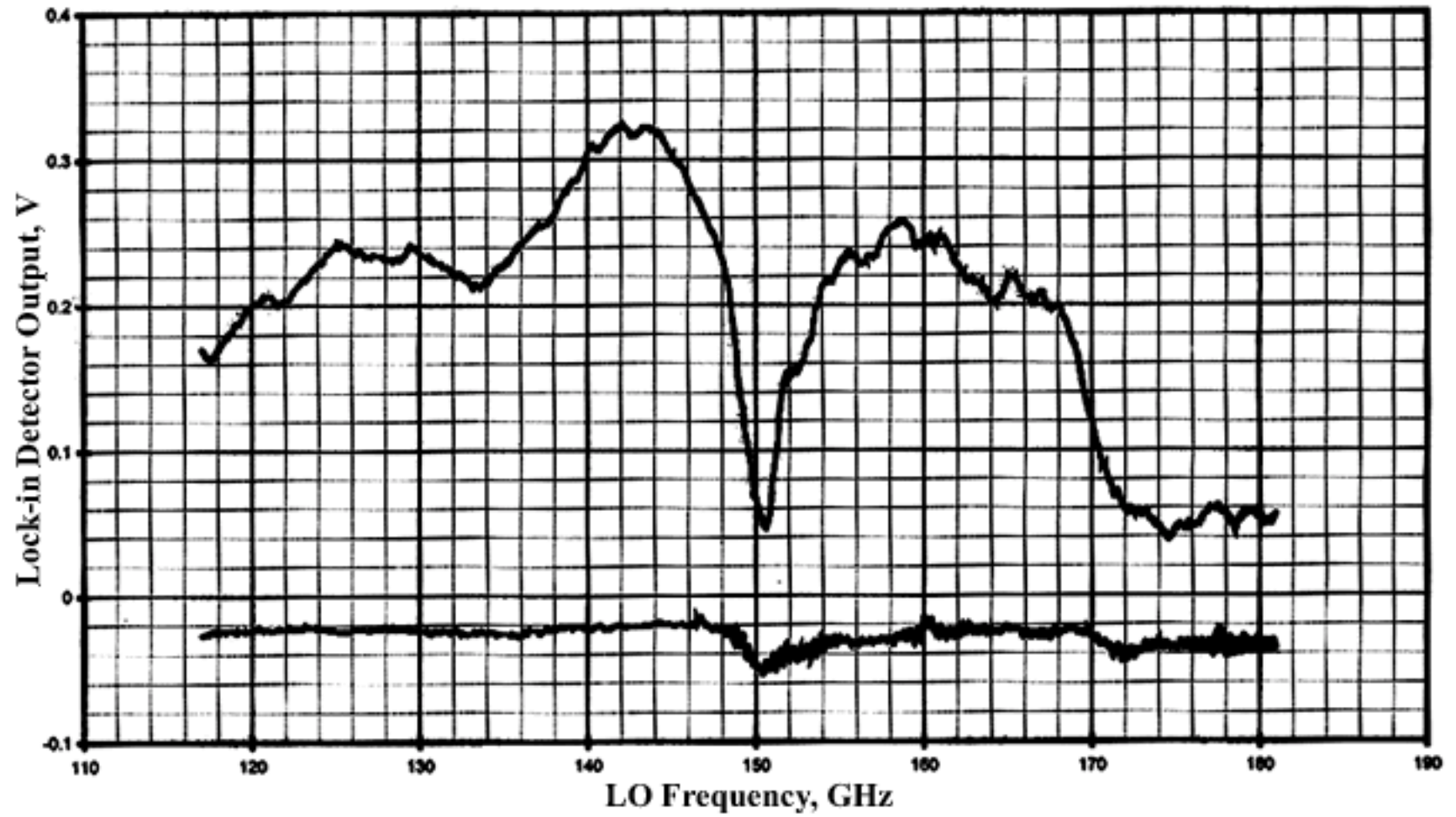

Fig. 7 Scheme of calibration by means of Liquid Nitrogen Cooled Matched Load

Liquid Nitrogen Calibration

Fig. 8



Conversation Losses vs. Frequency

Fig. 9

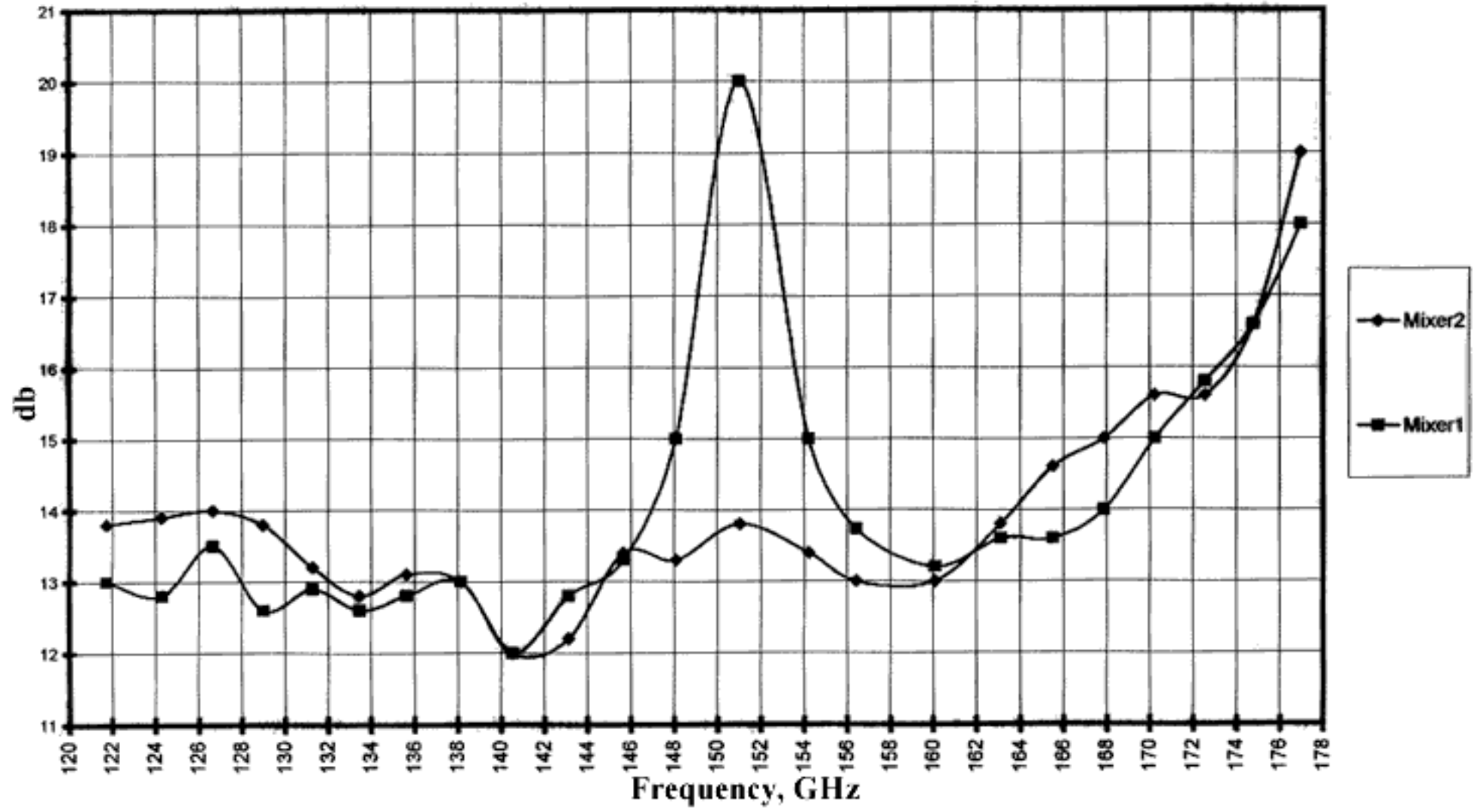

Noise factor vs. Frequency

Fig. 10

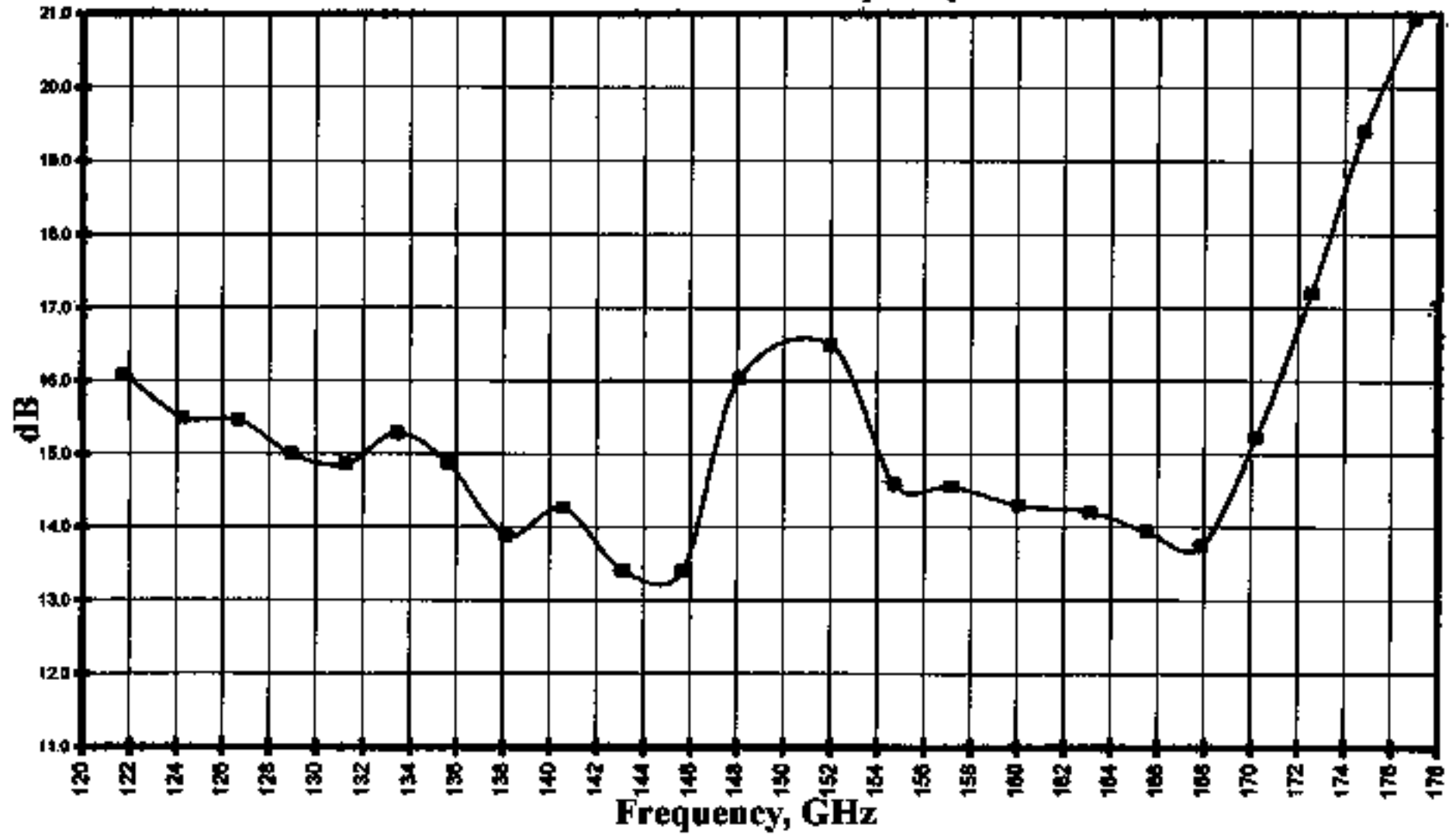
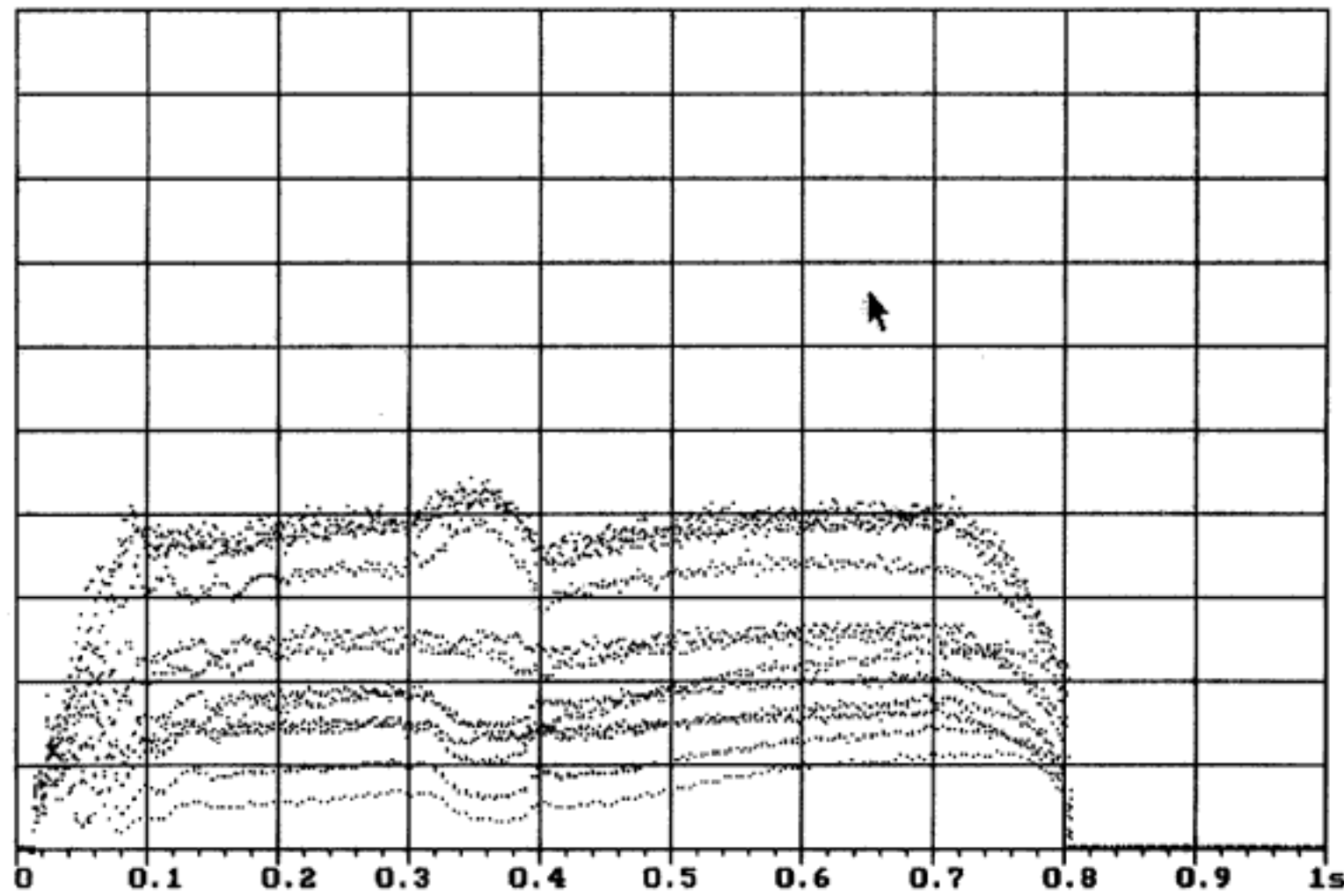

Fig. 11

Data file : res\03228.res



0
FileName
DrawStep
DrawData
CInScr
LOStart
DrawProf
WaitTrig
8
9
10
11
12
13
14
15
16
17
18
19
20

DOK&Co. presents the program for MSR!

Temperature Profile (Time=133 mS)

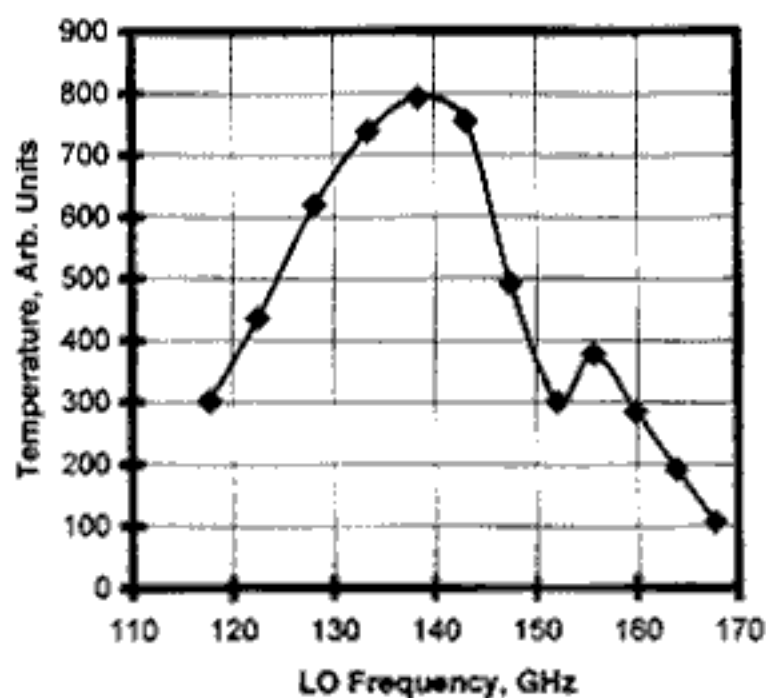

Temperature Profile (Time=225 mS)

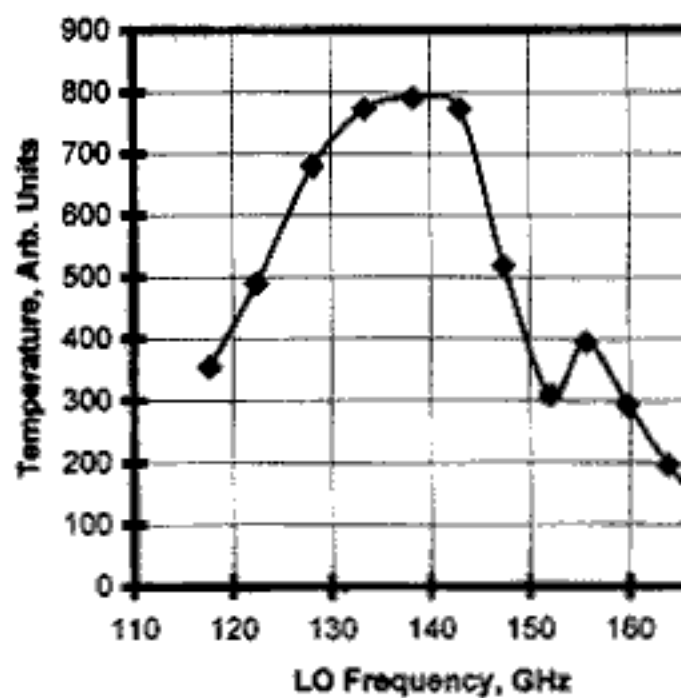

Temperature Profile (Time=320 mS)

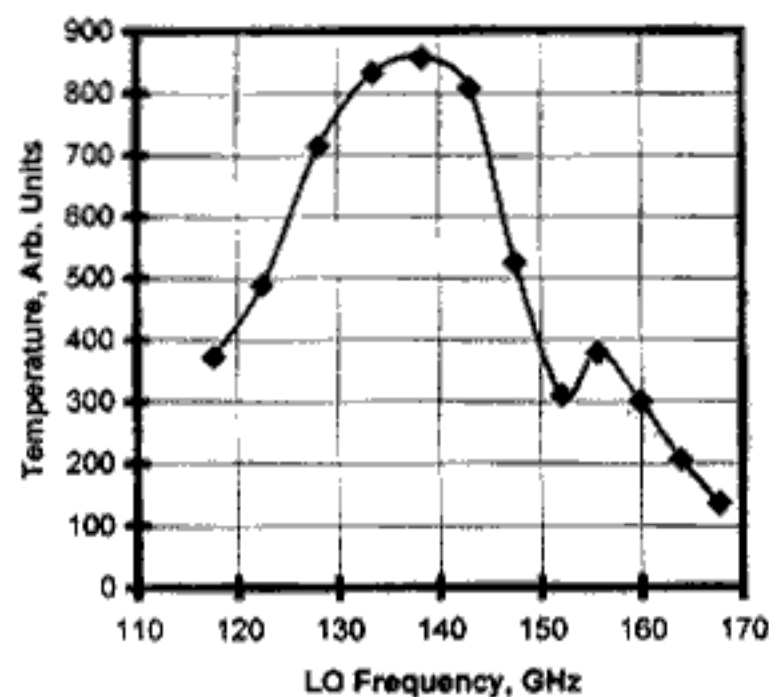

Temperature Profile (Time=455 mS)

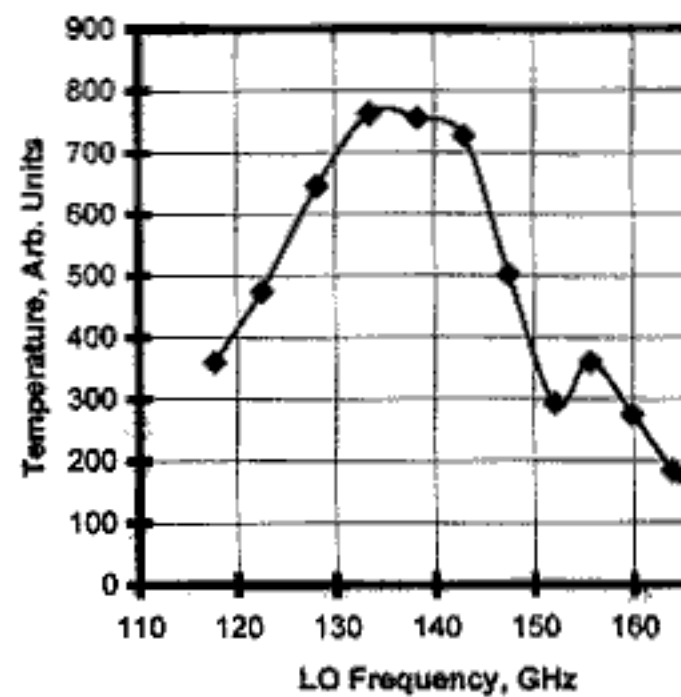

Temperature Profile (Time=550 mS)

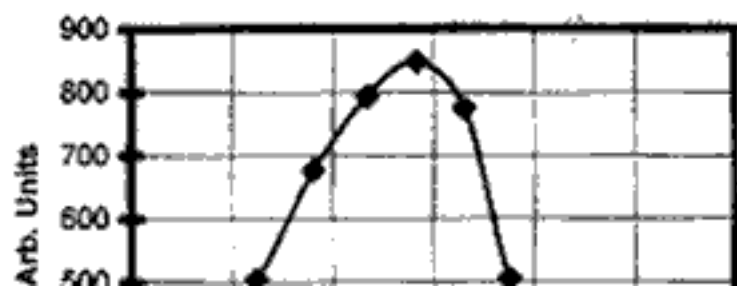

Temperature Profile (Time=640 mS)

