



46 Robezu str. LV-1004 Riga Latvia

Fax : +371-7-065102

Mm-wave Division in St. Petersburg, Russia

Fax: +7-812- 326-10-60

Tel: +7-812-326-59-24

E-mail: [ivanovph@nnz.ru](mailto:ivanovph@nnz.ru)

## Power Supply Modules for Clinotron Tubes



Operation manual  
(1-st edition, 10.09.2003)

## Contents:

<b>1. Introduction.....</b>	<b>3</b>
<b>2. Parameters and specifications .....</b>	<b>4</b>
<b>3. Design and mode of functioning.....</b>	<b>6</b>
<b>3.1 Functional Units.....</b>	<b>6</b>
<b>3.2 High Voltage Power Unit.....</b>	<b>6</b>
<b>3.3 Heater Current Unit. ....</b>	<b>6</b>
<b>3.4 Analog Control &amp; Protection Unit. ....</b>	<b>7</b>
<b>3.5 Microcomputer.....</b>	<b>7</b>
<b>3.6 Input for PLL Systems. ....</b>	<b>7</b>
<b>3.7 Stabilizers.....</b>	<b>7</b>
<b>3.8 Front Panel of Control Unit (Fig. 1).....</b>	<b>8</b>
<b>3.9 Rear panel of Control Unit (Fig. 2). ....</b>	<b>9</b>
<b>3.10 Front panel of HV Power Unit (Fig. 3). ....</b>	<b>9</b>
<b>3.11 Rear panel of HV Power Unit (Fig. 4).....</b>	<b>9</b>
<b>3.12 Internal and External control modes.....</b>	<b>10</b>
<b>3.13 Protections. ....</b>	<b>10</b>
<b>4. OPERATING MANUAL .....</b>	<b>11</b>
<b>4.1 Preoperational switching on. ....</b>	<b>11</b>
<b>4.2 Putting into operation.....</b>	<b>12</b>
<b>4.3 Set output power .....</b>	<b>12</b>
<b>4.4 Choosing HV control mode.....</b>	<b>12</b>
<b>4.5 Internal mode: fixed output voltage.....</b>	<b>12</b>
<b>4.6 Internal mode: sweeping output voltage.....</b>	<b>13</b>
<b>4.7 External voltage control mode.....</b>	<b>13</b>
<b>4.8 Fast checking the output voltage and the HV Stabilizer tubes..</b>	<b>13</b>
<b>4.9 Setting GPIB address of the device .....</b>	<b>14</b>
<b>4.10 GPIB interface.....</b>	<b>14</b>
<b>4.11 Examples of PSM operating via GPIB interface .....</b>	<b>15</b>
<b>4.12 Training procedure.....</b>	<b>17</b>
<b>5. Figures.....</b>	<b>18</b>
<b>5.1 Figure 1. Front panel of the Control Unit .....</b>	<b>18</b>
<b>5.2 Figure 2. Rear panel of the Control Unit.....</b>	<b>19</b>
<b>5.3 Figure 3. Front panel of HV Power Unit .....</b>	<b>20</b>
<b>5.4 Figure 4. Rear panel of HV Power Unit.....</b>	<b>21</b>
<b>5.5 Figure 5. Block diagram of PSM control circuits. ....</b>	<b>22</b>
<b>5.6 Figure 6. Scheme of connection PSM with Clinotron. ....</b>	<b>23</b>
<b>5.7 Figure 7. The diagram of the Output Voltage and strobes.....</b>	<b>24</b>
<b>5.8 Figure 8. Calibration data.....</b>	<b>25</b>

## 1. INTRODUCTION

Being intended primarily for feeding Clinotron tubes, Power Supply Modules PSM-300/5 (hereinafter referred to as PSM) may be used for other purposes as well. It delivers stabilized accelerating negative voltage within range of -1 kV down to -4.5 kV and stabilized current for the cathode heating up to 6A DC. Power supply consists of two units: the control unit and the power unit. Accordingly, there are two outputs in PSM, the high voltage output being adjustable under both manual or remote control modes. Gradual increasing the cathode heater current up to its operating value when switching the Clinotron tube on and gradual decreasing when switching off are carried out automatically. An embedded microcomputer facilitates the PSM control. The device protects both the Clinotron supplied and itself against overloading but **it is not protected against high voltage short-circuit failure outside PSM**. PSM is designed for being used in laboratory conditions.

Abbreviations used:

ACP –	Analog Control & Protection unit;
DAC –	Digital-to-Analog Converter;
HV –	High Voltage;
LED –	Light Emission Diode;
LCD –	Liquid Crystal Display;
MC –	built-in MicroComputer;
OA –	Operational Amplifier;
PSM –	Power Supply Module PSM-300/5.

## 2. PARAMETERS AND SPECIFICATIONS

### High voltage output:

Voltage control range	-1000 V to -4500 V
Maximum current	250 mA
Long term voltage stability	$10^{-5}$
Ripples and noise	<100 mV
Discretization when setting the voltage	10 mV
Uncertainty of the output voltage measurement	<0.02%
Overload protection response time	<50 $\mu$ s

Both the voltage and the current are displayed on LCD

Voltage adjustment: direct keyboard entry or pseudo-Analog rotary adjustment

Operational modes: fixed output voltage and sweeping output voltage

External Analog signal for output voltage control: 0 to +10V

IEEE488 interface

### Cathode heater current output:

Current control range	1 to 6 A
Maximum voltage	10 V
Long term current stability	$5 \times 10^{-3}$
Ripples and noise	<2 mA
Discretization when setting up the voltage	10 mV
Uncertainty of the output current measurement	0.5%
Overload protection response time	<20 ms

Both the voltage and the current are displayed on LCD. Minimum indicated level for current is 0.1A and for voltage – 0.3V.

Adjustment of output current with high-precision variable resistor

Gradual increasing the current up to the operating value for 1 min. when switching the CLINOTRON tube on and gradual decreasing when switching off for 30 sec.

IEEE488 interface for parameter reading only

All the parameter values above are valid after 30 min warming-up period.

**Electrical resistance between the power inlet and the housing:**

at normal conditions	>100 MOhm
at high temperature	>5 MOhm
at high humidity	>3 MOhm

**Primary Supply:** (110±5)V/(50+10)Hz.

**Power consumption:**

**Control unit** <300 VA.

**Power unit** <2 kVA

**Dimensions of each unit:** 480×295×560 mm.

**Weight:**

**Control unit** not more than 40 kg.

**Power unit** not more than 70 kg.

**Ambient conditions:**

air temperature	5 to 40°C
air humidity	up to 95% at 30°C
atmospheric pressure	84 to 112 kPa

**Clinotron oscillator:**

Operating cathode voltage:	-2850...-4500 V
Operating cathode current (max):	250 mA
Operating heater current (max):	5.4 A
Cooling water system (min):	2 liters/min

**Warranty:** 1 years.

### 3. DESIGN AND MODE OF FUNCTIONING

#### 3.1 Functional Units.

PSM consists of following functional blocks: High Voltage Power Unit (-1...-5kV), High Voltage stabilizer, Heater Current Unit (0...6A), Analog Control & Protection Unit (ACP), built-in Microcomputer (MC), Turning systems and Stabilizers (See Fig. 5).

Fig. 1, the Front Panel of Control unit, exhibits all PSM controls (switches, knobs, keys and indicators). Placement of connectors and sockets on the Rear Panel is shown on Fig. 2. Fig. 3 represents the Front panel of Power unit and Fig. 4 - rear panel.

The **High Voltage Power Unit** delivers the stabilized HV potential for grounded anode Clinotron tubes, output frequency being controlled with voltage variations.

High Voltage stabilizer controls HV cathode voltage and is placed into the Control unit.

The **Current Unit** is intended for feeding the Clinotron cathode heater. The Clinotron output power is defined by the cathode temperature, therefore it is controlled with changing the heater current. The Unit delivers the direct cathode heater current for Clinotron frequency instabilities driven by heater current variations to be suppressed. As it has been mentioned above, the heater current is increased gradually from zero up to the operating level for about 1 min. when putting the CLINOTRON tube into operation, and decreased for about 30 sec. when switching it off.

**Analog Control & Protection Unit (ACP)** monitors the current state of main PSM systems and turns off the output voltage and the heater current if the Clinotron cathode current exceeds its upper limit.

The built-in **Microcomputer (MC)** controls HV, Current and Overload Protection Units.

**Stabilizers** supply all the PSM units with the power.

#### 3.2 High Voltage Power Unit.

This unit consists of a block of HV transformers, rectifiers and HV ACP.

The secondary winding of the HV Transformer contains several separate isolated sections, each of them having its own rectifier. The net rectified voltage is sum of the partial ones.

The High Voltage Power unit (physically specially constructed as an external device because of its high heat power) is a set of vacuum triodes connected in series with the rectifier. It is controlled with a signal produced by HV stabilizer, placed into the Control unit. A signal (within a range of 0 to +10 V) which determines the output voltage, may be either produced by MC inside the Control unit or received from the outside when operating under the External control mode. Being used as the reference voltage, it is compared by OA placed in HV stabilizer, with signal received from output voltage divider made of high-precision resistors. The comparison signal comes to the HV Stabilizer input.

#### 3.3 Heater Current Unit.

is composed of current stabilizer, control circuit, decoupled HV converter and decoupled power supply unit.

As it has been mentioned above, **the current stabilizer** operates at the constant current mode. The desired output current is adjusted with the high-precision variable resistor on the front panel of the Control unit.

**Control circuit** turns off both the cathode and the heater voltages when the heating current exceeds 6A. Another its function is to run the procedure of gradual increasing/decreasing the heater current at switching the Clinotron tube on/off. The unit indicates status of the current stabilizer and does not allow applying the cathode voltage until the heater current will reach the operating value.

**The HV decoupled converter** produces data on status of the stabilizer and the control unit to be sent to MC. The converter is isolated from HV circuits.

**The decoupled power supply** delivers the power supply for all the Current Unit systems whereby the Current Unit turns out to be isolated from the rest components of PSM.

### **3.4 Analog Control & Protection Unit.**

monitors the current state of main PSM systems and generates control signals for all PSM protection circuits. The cathode current overload protection circuit is intended to switch off the HV Transformer and the Heater Current Unit when the cathode current becomes higher than 250mA. Another control circuit doesn't allow to switch the HV Unit on until the cathode warming-up process is accomplished. "No water" protection circuit switches off the HV Transformer and the heater current and lights indicator if no water is in the Clinotron cooling system.

### **3.5 Microcomputer.**

MC is an industrial IBM PC compatible device built into PSM. Together with DAC it carries out interacting between different PSM blocks and units. It is also used for manual controlling PSM by means of Front Panel controls or for a remote control via GPIB bus.

### **3.6 Input for PLL Systems.**

"INPUT PLL" is intended for keeping the Clinotron frequency constant is used, the external control signal has be added to cathode voltage.

### **3.7 Stabilizers.**

The output parameters of the Stabilizers are as follows:

- ±15V/1A DC for feeding OA and Analog circuits;
- +5V/1A for feeding digital circuits;
- +24V/2A for feeding relays;
- +5V/5A for feeding MC;
- +12V/1A for feeding MC;
- +100V/0.5A for feeding grids of the vacuum tubes;
- 6V/3A AC for feeding cathode heaters of vacuum tubes.

### 3.8 Front Panel of Control Unit (Fig. 1).

- HV switch (1) to turn the high voltage transformer ON or OFF;
- POWER switch (2) to turn the power ON or OFF. PWR indicator (7) is lit when the power is ON and unlit when the power is OFF;
- The heater current knob (3) to handle the heater current high-precision variable resistor;
- RESET button (4) to restart the Microcomputer;
- WATER indicator (5) is lit when there is no water in the cooling system;
- PREHEAT indicator (6) is lighting during the cathode warming-up;
- READY indicator (8) is lit when the cathode warming-up is completed;
- LOCK indicator (9) is lit when the second HV section of transformers is ON;
- +5 indicator (10) is lit when +5 V Microcomputer supply is ON;
- +12 indicator (11) is lit when +12 V Microcomputer supply is ON;
- HV TR ON indicator (12) is lit when the first section of HV transformers is ON;
- HEAT OVER indicator (13) lights up at heater current overloading;
- HV OVER indicator (14) lights up at cathode current overloading;
- Digital Keyboard (15).
- Knob for precise output voltage setting (16);
- Two STEP buttons (17) for precise output voltage setting;
- OUTPUT CONTROL button (19) to toggle External and Internal HV control modes. LED inside the button is lit when the External mode is ON (the external 0...+10 V control signal has to be applied to INPUT socket (18) for remote controlling the output high voltage). LED inside the button is unlit when the Internal mode is ON and the output voltage is controlled by the Microcomputer through DAC;
- MENU button (20) to display the operation menu on LCD (26);
- HEATING switch (22) to turn ON the cathode warming-up. LED inside the button is lit when the cathode warming-up is ON;
- HEATING switch (21) to turn OFF the cathode warming-up. LED inside the button is lit when the cathode warming-up is OFF;
- LOCK button (23) is not used in this configuration;
- HIGH VOLTAGE button (24) to switch the high voltage ON or OFF, LED inside the button is lit when HV is applied to CATHODE outlet (36, Fig. 2) on the Rear Panel;
- PLL input BNC connector (25) for external PLL signal;
- LCD (26) to display the PSM regimes;

### **3.9 Rear panel of Control Unit (Fig. 2).**

- 110AC is primary 110 VAC power supply inlet (27) with integrated fuse 4A;
- GROUND socket (28);
- GPIB terminal (29) for connecting GPIB bus;
- CONTROL connectors (30). BNC connector delivers TTL pulses synchronized with output voltage sweeps. Diagram of the output voltage sweeping and the strobe TTL pulses are shown on Fig. 5, multi-pins connector provides control signals for HV Power unit.
- WATER input terminal (31), isolated from the housing and optically decoupled with other circuits, for external signal about filling the CLINOTRON cooling system with the water;
- HV MONITOR output BNC terminal (32) intended for monitoring the output high voltage (pay attention that 1.6...+10 V on the Monitor corresponds to -1...-5kV on the HV output);
- SVGA terminal (33) for connecting an external SVGA monitor;
- KEYBOARD terminal (34) for connecting an external keyboard;
- MOUSE terminal (35) for connecting PSM to RS-232 bus;
- FEEDBACK (black line) HV feedback for HV Power unit (-1...-5 kV) outlet (36).
- HEATING 1 (green line) heater current (0...6 A) outlet (37);
- HEATING 2 (yellow line) heater current (0...6 A) outlet (38);
- Fan (39).

### **3.10 Front panel of HV Power Unit (Fig. 3).**

- Power switch (40).

### **3.11 Rear panel of HV Power Unit (Fig. 4).**

- Fans (41);
- FEEDBACK, HV feedback (black line) outlet (42);
- CATHODE, cathode feeding (white line) outlet (43);
- Multi pins control connector (44);
- Power plug 110 VAC (45);
- Primary Power switch (46).

### 3.12 Internal and External control modes.

There are two modes of the high voltage (i.e. Clinotron frequency) control, Internal and External. The modes are toggled with the OUTPUT CONTROL button on the Front Panel (19, Fig. 1). When toggling into the Internal mode, a relay connects MC to the control input of the HV Unit (LED inside the button is unlit). Then the following regimes are available: fixed HV, fixed HV with Additional External Analog Voltage Control, sweeping HV, the output voltage being set manually with the controls of the Front Panel or through the GPIB interface.

At the sweeping mode, the cathode voltage variations are linear in time (Fig. 7) with 7 fixed sweeping rates: 2, 4, 8, 10, 20, 80 and 100 sec are the rise times. MC displays minimum and maximum values of the sweeping voltage.

At the external control mode (LED inside the button (19) is lit) the relay connects INPUT socket (18) to the control input of the HV Unit (the control signal 0...+10 V has to be applied to the socket (18) from the outside). Then the output high voltage (-1...-5 kV) corresponds to the control signal (0...+10 V).

### 3.13 Protections.

In PSM the heater current is increased gradually from zero up to the operating level for 1 min. when putting the Clinotron tube into operation. The high voltage can not be applied to the cathode until the heater current will reach the operating level. At turning Clinotron off, the high voltage is switched off prior to beginning of the heater current decay, which lasts for 30 sec.

To prevent CLINOTRON against mistaken applying too high cathode voltage, an automatic limitation of the output voltage is provided. The limitation is available when operating under the Internal control mode only.

Three emergency protections are provided in PSM: when the cathode current exceeds 250 mA, when the heater current exceeds 6 A and when the water flow stops in the Clinotron cooling system. In all of three cases HV and the heater current are switched off, a sound signal is induced and the cause of the emergency is displayed on LCD. In order to switch PSM on again, it is necessary to turn whole the device off, to eliminate the cause and then turn PSM on. The off-water protection responds in a case if the WATER input terminal (31, Fig. 2) is opened. For normal operation Water input terminal should be short circuited outside PSM.

Pay attention that **PSM is not protected against high voltage short-circuit failure outside the device**. Such a failure would produce serious damages almost in all the units.

## 4. OPERATING MANUAL

### ATTENTION!

Prior to put PSM into operation, make the acquaintance of schemes of device grounding (Fig. 5). Before turning on the Generator, ensure that device is properly grounded using the corresponding contact "GROUND" (28).

Remember that **PSM is not protected against high voltage short-circuit failure outside the device**. Make certain of that there is no short circuiting the high voltage to the ground in the CLINOTRON tube assembly.

### 4.1 Preoperational switching on.

This preparation is carried out with no turning HV on. The objective is to determine the heater current that will be set later, during actual operating according to the chosen position of the heater current resistor (3, Fig. 1).

Ground PSM according to Fig. 6.

Ensure that fuses are installed.

### NOTES.

- **For all connections please use cables according to colour marking only.**
- **Cables for heater are specially grounded from one end only.**
- **Clinotron's circuit is grounded via cathode (white) line only.**
- **Recommended for additional safety to use grounding of Clinotron's unit via separated wire.**

Install short circuiting crowbar onto the heater current output (37, 38, Fig. 2) (Make the heater output short circuited).

Rotate the heater current knob (3, Fig. 1) counterclockwise to the stop.

Turn the POWER switch (2, Fig. 1) ON, then RESET knob for starting MC. The PWR, +5 and +12 indicators (7, 10 and 11, Fig. 1, respectively) light up. LCD (26, Fig. 1) displays the current time. Then, about 4 sec. later, the main menu will appear. LED inside the HEATING OFF switch (21, Fig. 1) is lit.

Press the HEATING switch to turn the cathode warming-up ON (22, Fig. 1), LED inside the button will lit. LCD displays "Preheating ON wait  $U_h = \dots V$ ,  $I_h = \dots A$ ". In about 2 min., after a sound signal, another screen menu will be displayed: " $U_c = \dots V$ ,  $U_h = \dots V$ , HV OFF,  $I_h = \dots A$ " and the READY indicator (8, Fig. 1) will light.

Set the operating heater current (4.8A) with the heater current knob (3, Fig. 1). The current is displayed in the " $I_h = \dots A$ " item of the screen menu (min indicated level is 0.13A).

Set upper limit of the output high voltage. Press the MENU button (20, Fig. 1). The menu screen, "1.Manual 2.Sweep 3.Mode .kV, 4.Monitor", is displayed on LCD. Press "3" digit key on the keyboard (15, Fig. 1), then choose the upper limit in kV by pressing "4", "5" or "6" digit keys. Press the MENU button again: the limit chosen will be stored for the next switchings-on of the device and setting a higher voltage will not be allowed while operating under Internal control mode. (In this issue max HV voltage is fixed and set on 4.5kV)

Turn the POWER switch (2, Fig. 1) OFF.

In about one minute (for a residual cathode voltage to decay) the CLINOTRON tube may be connected to PSM following to one of schemes of Fig. 6 and water cooling system.

The device is ready for operating.

All the settings are stored automatically in MC flash memory. The last settings are loaded automatically at restarting or at the next turn-on.

## 4.2 Putting into operation

### ATTENTION!

- **After keeping Clinotron without operation more then one week, it must essentially pass a training procedure. The training procedure is described in Section 4.12.**
- **Please be aware that cooling water system operates properly. The absence of the cooling provides damage of Clinotron immediately.**

Compose system according to Fig. 6, then **apply cooling water system**, turn on the power with the switch (2, Fig.1) and the heater warming-up with the switch (22, Fig.1). Heater current level should be 4.8...4.9 A.

After the READY indicator (8, Fig. 1) will have lit, turn the HV switch (1, Fig.1) ON to apply the power to the HV transformer.

Press HIGH VOLTAGE button (24, Fig. 1) to switch the high voltage ON, LED inside the button lights up and HV is applied to the CATHODE outlet (43, Fig. 4) on the Rear Panel.

Set Cathode voltage at 3000V and after waiting about 5 minutes (cathode current should be stabilized) to set desired operating currents and then device is ready for operation.

## 4.3 Set output power

Output power can be controlled by variation of the heater current. Recommended to do that the following way:

- set heater current at 4.6...4.8A level
- set cathode voltage according to applied calibration data
- smoothly increasing heater current to achieve desired output power (see Fig. 8)
- recommended max levels for operation:  $I_{\text{cathode}} = 230 \text{ mA}$ ,  $I_{\text{heater}} = 5.3 \text{ A}$

## 4.4 Choosing HV control mode

Having PSM turned ON, the HV control mode should be chosen, i.e. Internal or External ones. They are toggled with the OUTPUT CONTROL button on the Front Panel (19, Fig. 1). If the Internal mode is ON, LED inside the button is unlit. If the External mode is ON, LED inside the button is lit.

## 4.5 Internal mode: fixed output voltage

Once PSM is ON and the high voltage is applied to the CATHODE outlet (43, Fig. 4) on the Rear Panel, one should set the desired value of the output high voltage which is indicated in the "Uc=...V" item on LCD. If the Internal mode of the output voltage control is chosen there are four ways to perform it:

Rotate the Knob for precise setting the output voltage (16, Fig. 1). The output voltage varies synchronously with the value indicated on LCD.

Press the STEP ← or → buttons (17, Fig. 1). Each the button pressing changes the output voltage by 0.01 V. The output voltage varies synchronously with the value indicated on LCD.

Enter the value of voltage from the Digital Keyboard (15, Fig. 1). A marker will appear on LCD just after the first digit key releasing. The STEP ← or → buttons (17, Fig. 1) may be used for changing the marker position whereby editing the voltage value may be performed with that aid of the display. Press key “Enter” to complete editing and to make the output voltage changed. If the value set with this way appears to be beyond the voltage limit preset earlier (see Section 4.1) it will be set as **the new limit**.

#### **4.6 Internal mode: sweeping output voltage**

When using this mode, one should set all three sweep parameters: minimum and maximum voltage and the sweep period. Both the voltage increase and decrease are linear in time with equal rise and decay times (Fig. 5).

Press the MENU button (20, Fig. 1). When the MENU screen is displayed on LCD press the digital keys on the Digital Keyboard to display submenus: the keys "1", "2", "3", "4", "5", "6" correspond to submenus "Manual", "Sweep", "Mode ...kV", "Monitor", "GPIB address", "Service menu" respectively.

Press the key "2" to choose the submenu "Sweep". There are four commands in the submenu:

1. “U<sub>int</sub>” – sets initial voltage;
2. “U<sub>fin</sub>” – sets final voltage;
3. “Time” – sets sweep time;
4. “Start” – enables sweeping.

Press one of the keys "1" or "2" to set the sweeping voltage min/max values. Use the procedures described in Section 4.4.

Press the key "3" to set the sweep period. As it has been mentioned in Section 3.10, only 7 values, 2, 4, 8, 10, 20, 80 and 100 sec, are available. At attempt to set a fault value the nearest available one will be selected and set automatically.

Press the key "4" to enable sweeping. The sweep voltages will be displayed. The TTL strobe pulses are generated at the beginning of each sweep period (Fig. 5) and applied to the CONTROL output connector (30, Fig. 2). Use them for triggering external devices.

Press the MENU key to stop sweeping.

#### **4.7 External voltage control mode**

As it has been mentioned in Section 3.10, when this mode is used the external positive signal has to be applied to the INPUT socket (18, Fig. 1), the output high voltage, -1...-6 kV, corresponding to the control signal, 0...+10V. Set the External mode following to the directions in Section 4.3.

#### **4.8 Fast checking the output voltage and the HV Stabilizer tubes**

When the MENU screen is on LCD press the key "4" to open the “Monitor” submenu. Information “HVmonitor=...V” (the actual output voltage) and “Ugrid=...V” (the voltage

applied to grids of the Stabilizer vacuum triodes) is displayed. A rough digitalizing is used in these measurements.

#### 4.9 Setting GPIB address of the device

GPIB interface card is integrated into Controller and initialized automatically in device (slave) mode. PSM Microcomputer address, which may be equal to one of integer numbers from 01 to 20 should be set onto the GPIB bus. MC saves the address in its flash memory and reinstalls it automatically when restarting.

When the MENU screen is on LCD press the key "5". "GPIB address .." appears on LCD where ".." is a previously installed address.

Press the digit keys to enter new two digit address.

Press the MENU button to complete the new address installation.

#### 4.10 GPIB interface

PSM may be fully controlled from a remote computer through the GPIB interface. The same sequence of commands as used in the manual control mode may be sent to PSM. The commands are coded by ASCII symbols. On the other hand the complete information about the PSM current settings may be received.

Connect the GPIB bus to the GPIB terminal (29, Fig. 2) on the Rear Panel of PSM using special cable.

Put PSM into operation as directed in Section 4.2.

Correspondence between the buttons and the digital keys on the Front Panel to be pressed in the manual mode and the ASCII symbols to be sent to PSM via GPIB bus are shown in the table below (the numbers in the brackets are positions in Fig. 1):

Keys and Buttons of the PSM Front Panel	GPIB port symbols
Decimal digits 0 to 9 (15)	0 to 9
Decimal point (15)	.
ENTER (15)	e
High Voltage ON/OFF (24)	A
POLARITY HEATING LOCK/reversing (23)	B
HEATING ON (22)	C
HEATING OFF (21)	D
MENU (20)	q
OUTPUT CONTROL EXTERNAL/INTERNAL (19)	F
STEP ← (17)	l
STEP → (17)	r

The current PSM settings may be read via GPIB bus in form of "Status String"="Name\_Condition\_Uc\_Ic\_Ih\_Uh\_Uini\_Ufin\_Time\_ScreenCopy". It consists of 10 information words separated with blanks. The "Status String" dimension is variable and depends on the current status of PSM.

The "Name" word occupies first five bytes, from 1st to 5th. For the Power Supply Module, PSM, this word is fixed: "Name"="PSM16".

The "Condition" word occupies bytes from 7th to 14th. Correspondence between values of each "Condition" bit and the PSM settings are shown in the next table:

Regime	Bit	Value
Ready/Not Ready	28	1/0
No Water/ With Water	26	1/0
Heater Overload/No Overload	27	1/0
HV Overload/No Overload	30	1/0
External/Internal Control	15	1/0
HV ON/OFF	12	1/0
Heater OFF/ON	11	1/0
Lock ON/OFF	10	1/0

«Uc» describes the fixed output voltage in Volts.

«Ic» describes the cathode current in mA.

«Ih» describes the heater current in Amperes.

«Uh» describes the heater voltage in Volts.

«Uini» describes the minimum sweep voltage in Volts.

«Ufin» describes the maximum sweep voltage in Volts.

«Time» describes the sweep period in seconds.

“CopyScreen” contains 41 symbols displayed on LCD at the moment of the request. 20 first of them correspond to the first string of LCD, then <CR> symbol follows, the next 20 symbols correspond to the second string of LCD. <CR> bytes are standard.

#### **4.11 Examples of PSM operating via GPIB interface**

##### **Sweeping voltage mode**

Let us choose the following settings as an example:

voltage control mode – Internal;  
minimum sweep voltage – 1254V;  
maximum sweep voltage – 4136V;  
sweep period – 4 s.

First of all, the voltage control mode preset earlier is checked. Get “Status String”. If 15th bit of the “Condition” word is equal to 1, send ASCII symbol "F" for the Internal voltage control mode to be set. If the 15th bit is equal to zero, the Internal mode is set.

The sweep parameters are set by sending commands defined in section 4.5:

send "q" to enable the main menu function;  
send command "2" to enable the “Sweep” submenu and then command "1" to enable the submenu "U\_int";  
send “1” “2” ”5” ”4” to set the minimum sweep voltage and “e” – enter – to complete setting the minimum voltage;  
send “q” to return to the submenu "Sweep" and then "2" to enable the submenu "U\_fin";  
send “4” “1” “3” ”6” to set the maximum sweep voltage and “e” (i.e. "ENTER") to complete setting the maximum voltage;  
send “q” to return to the submenu "Sweep" and then "3" to enable the submenu "Time";  
send ”4”, the sweep period, and then “e”;  
send “q” – return and “4” – to start sweeping;  
send “q” to stop sweeping and to return to the main menu.

#### **Fixed voltage mode**

Let us choose the fixed voltage equal to 2165.12 V as an example.

Having set the Internal control mode and the main menu function as described above, send “1” to enable the “Manual” submenu;

send “2” “1” “6” ”5” ”.” ”1” ”2” then “e”;  
send “l” to decrease the fixed voltage by the minimum voltage step, 0.01 V, or “r” to increase;  
send “q” to return to the main menu.

#### **External control mode.**

Apply the external control signal 0...+10 V to the connector (18, Fig. 1).

Get “Status String”. If 15th bit of the “Condition” word is equal to zero, send ASCII symbol "F" for the External voltage control mode to be set. If the 15th bit is equal to 1, the External mode is set.

#### **Setting the GPIB address of the device**

Let a new address, say "4", have to be set.

Having the menu function enabled, send “5” to activate "GPIB address" menu;  
send “0” and “4” to set the new address;

send “q” to complete setting and return to the operating menu.

#### 4.12 Training procedure

- After preoperational procedure (Section 4.1), heater current should be set at 4.8A level, turn on **cooling water system**, then the power switch (2, Fig.1) and then the heater warming-up with the switch (22, Fig.1).
- After the READY indicator (8, Fig. 1) will have lit, turn the HV switch (1, Fig.1) ON to apply the power to the HV transformer.
- Press HIGH VOLTAGE button (24, Fig. 1) to switch the high voltage ON, LED inside the button lights up and HV is applied to the CATHODE outlet (43, Fig. 4) on the Rear Panel.
- Set Cathode voltage at 3000V and after waiting about 10 minutes to set heater current at 5.13A and after that Clinotron should operate during 10 minutes.
- Decrease heater current down to 4.8A.
- Set Cathode voltage at 3500V and after waiting about 10 minutes to set heater current at 5.13A and after that Clinotron should operate during 10 minutes.
- Decrease heater current down to 4.8A.
- Set Cathode voltage at 4000V and after waiting about 10 minutes to set heater current at 5.13A and after that Clinotron should operate during 10 minutes.
- Decrease heater current down to 4.8A.
- Set Cathode voltage at 4500V and after waiting about 10 minutes to set heater current at 5.13A and after that Clinotron should operate during 10 minutes. If Clinotron operates without internal discharges, it means that the Clinotron is ready for operation.

## 5. FIGURES

### 5.1 Figure 1.

Front panel of the Control Unit.

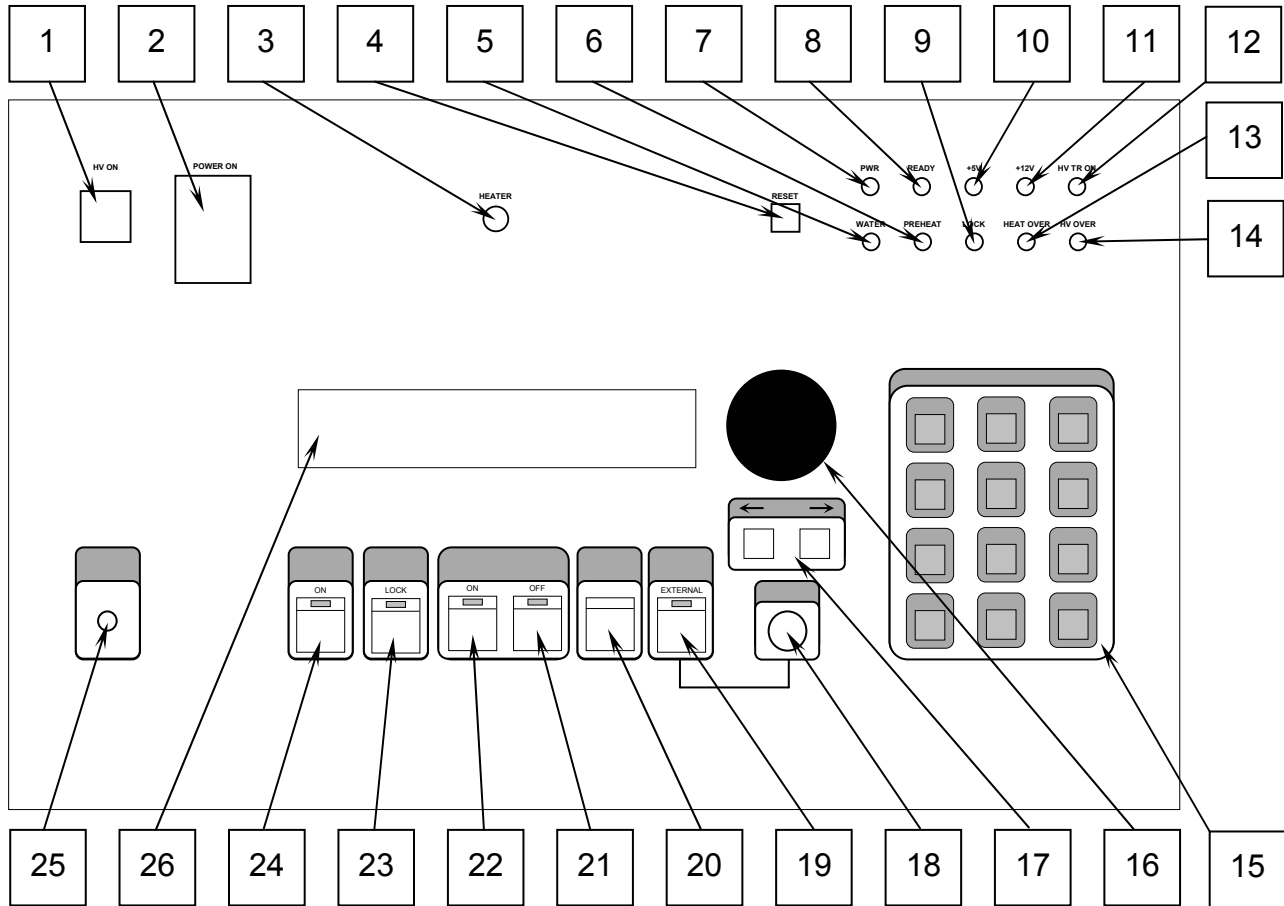

Disposition of the connectors and knobs on the front panel of the Control Unit.

No	Name	No	Name
1.	“HV ON” switch	15.	Digital keyboard
2.	“POWER” switch	16.	Tuning knob
3.	Heater current knob	17.	“STEP” buttons
4.	“RESET” button	18.	External voltage control 0...+10V, BNC connector
5.	“WATER” indicator	19.	External Voltage Control switch
6.	“PREHEAT” indicator	20.	“MENU” button
7.	“PWR” indicator	21.	“HEATING” switch off heater current
8.	“READY” indicator	22.	“HEATING” switch on heater current
9.	“LOCK” indicator	23.	“LOCK” is not used
10.	“+5” indicator	24.	“HIGH VOLTAGE” switch on/off
11.	“+12” indicator	25.	Input for PLL system, BNC connector
12.	“HV TR ON” indicator	26.	Liquid Crystal Display
13.	“HEAT OVER” indicator		

## 5.2 Figure 2

### Rear panel of the Control Unit.

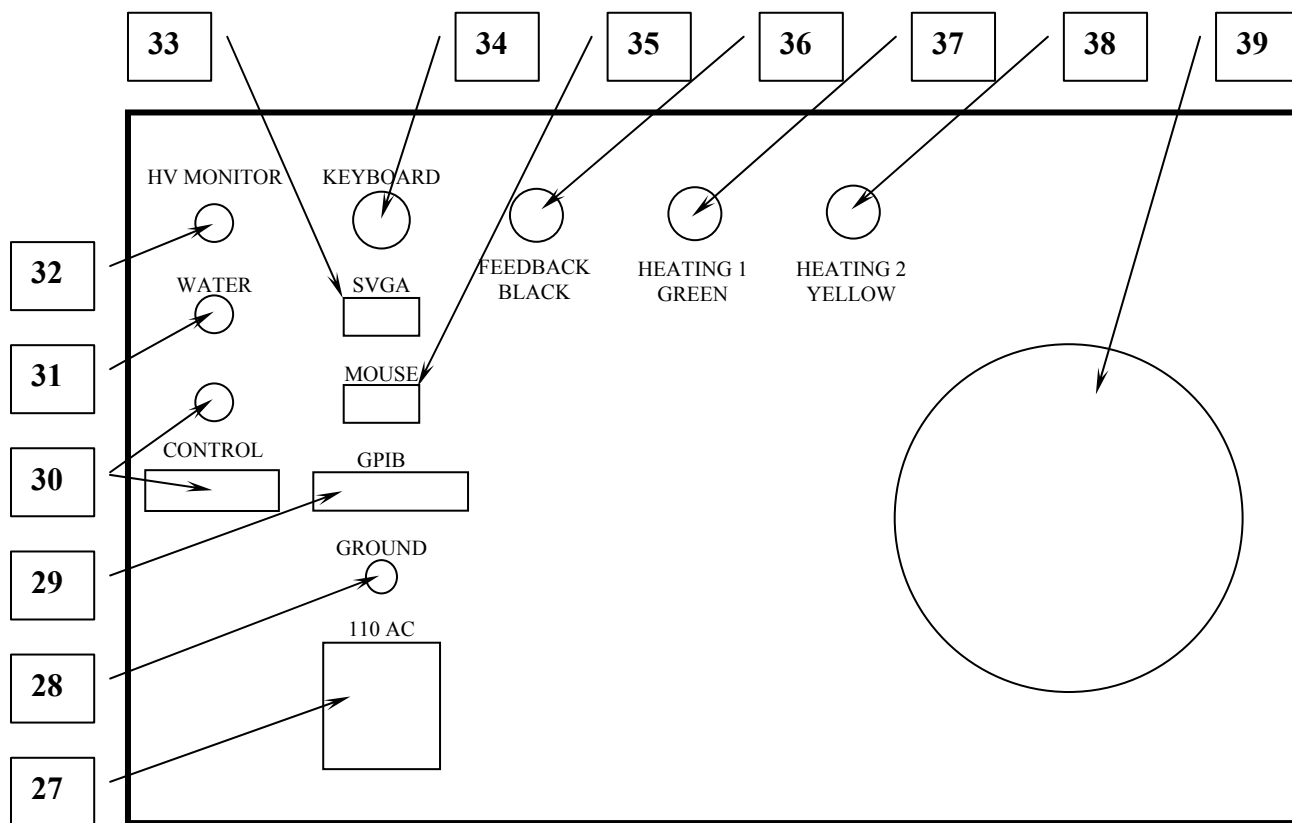

The disposition of the plugs and knobs on the rear panel of the Power Supply Module.

No	Name	No	Name
27.	"Power Plug" 110V AC, Fuse 4A	36	"FEEDBACK", connector for HV feedback
28.	"Ground", connector	37	"Heating 1 GREEN", HV connector of heater 1
29.	"GPIB" interface connector	38	"Heating 2 YELLOW", HV connector of heater 2
30.	"Control", output plugs	39	Fan
31.	"Water", BNC input plug		
32.	"HV Monitor", BNC output plug		
33.	"Monitor", SVGA interface plug		
34.	"Keyboard", interface plug		
35.	"Mouse", RS-232 interface plug		

### 5.3 Figure 3

#### Front panel of the HV Power Module.

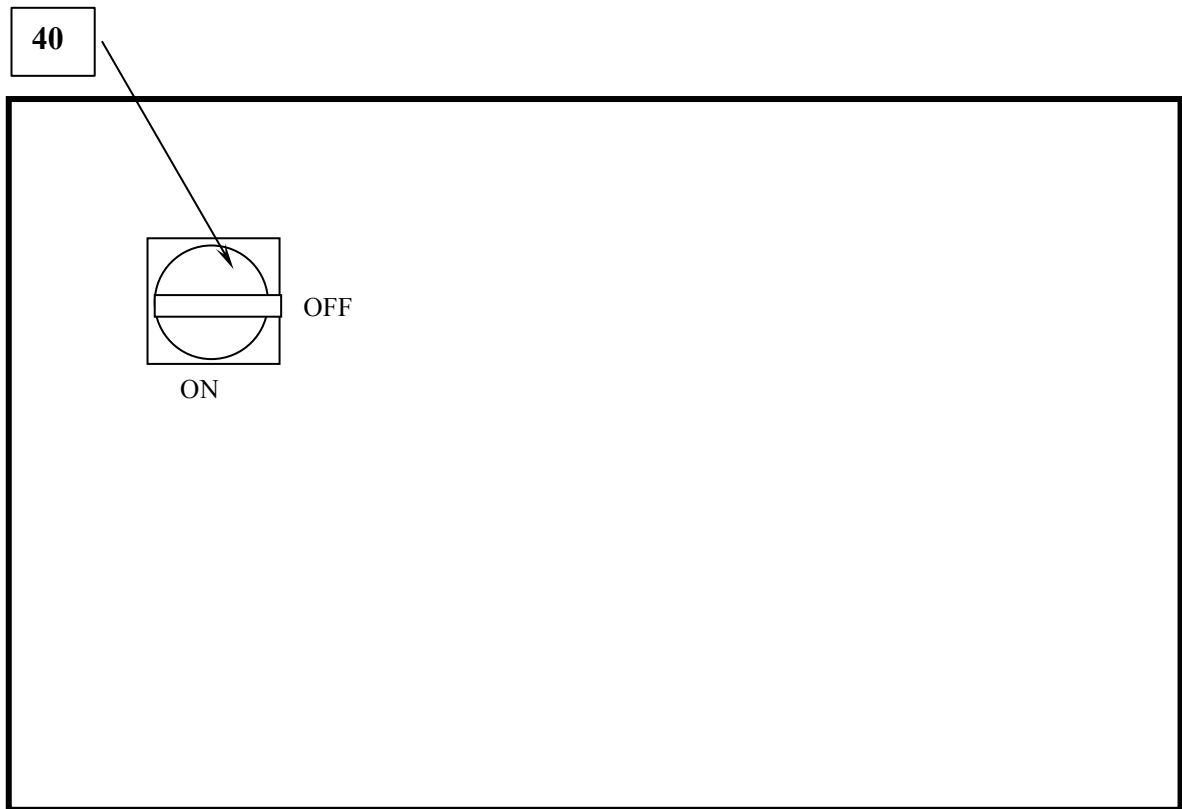

The disposition of the knob on the front panel of the HV Power Module.

No	Name	No	Name
40.	Power Switch		

**5.4 Figure 4**  
**Rear panel of the HV Power Module.**

The disposition of the plugs and knobs on the rear panel of the HV Power Module.

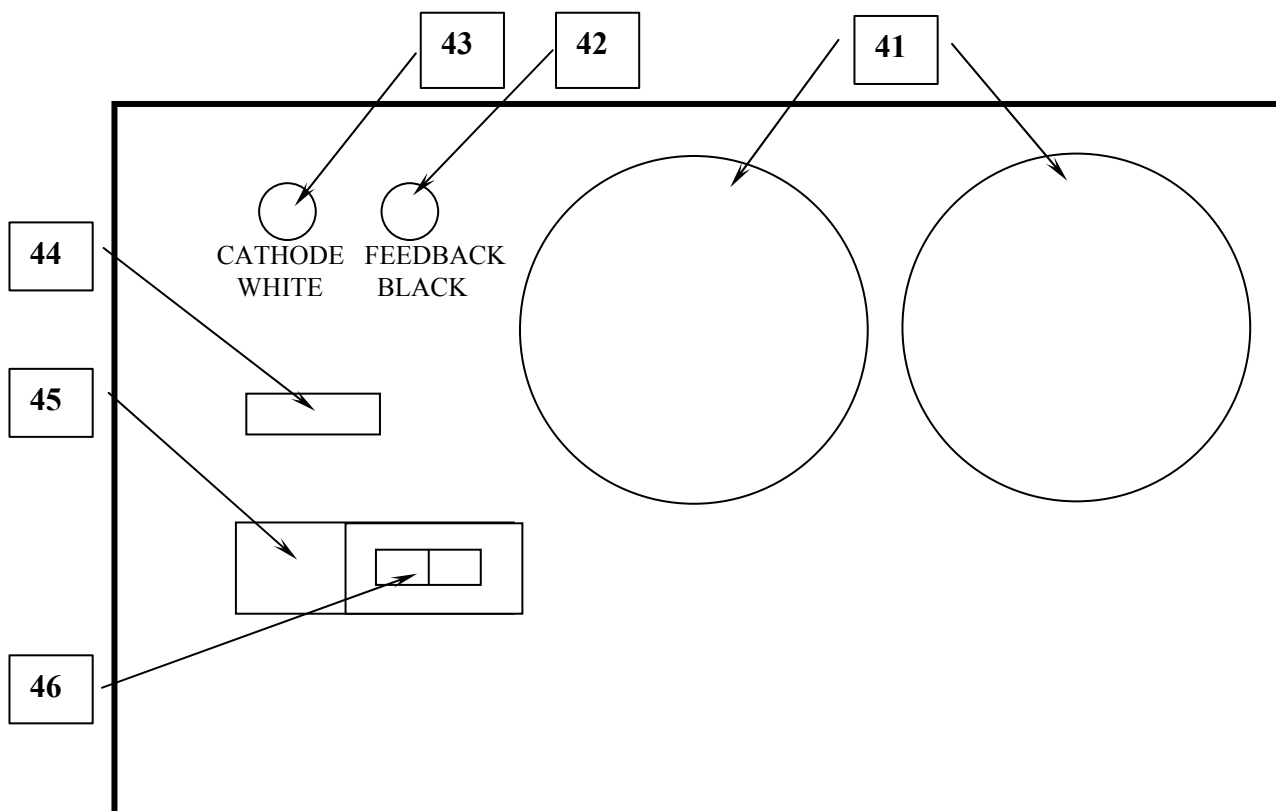

No	Name	No	Name
41.	Fans	44.	Multi pins Control Connector
42.	Connector for HV feedback	45.	Power Plug 110 VAC
43.	Connector to cathode	46.	Primary Power switch

5.5 Figure 5

Block diagram of PSM control circuits.

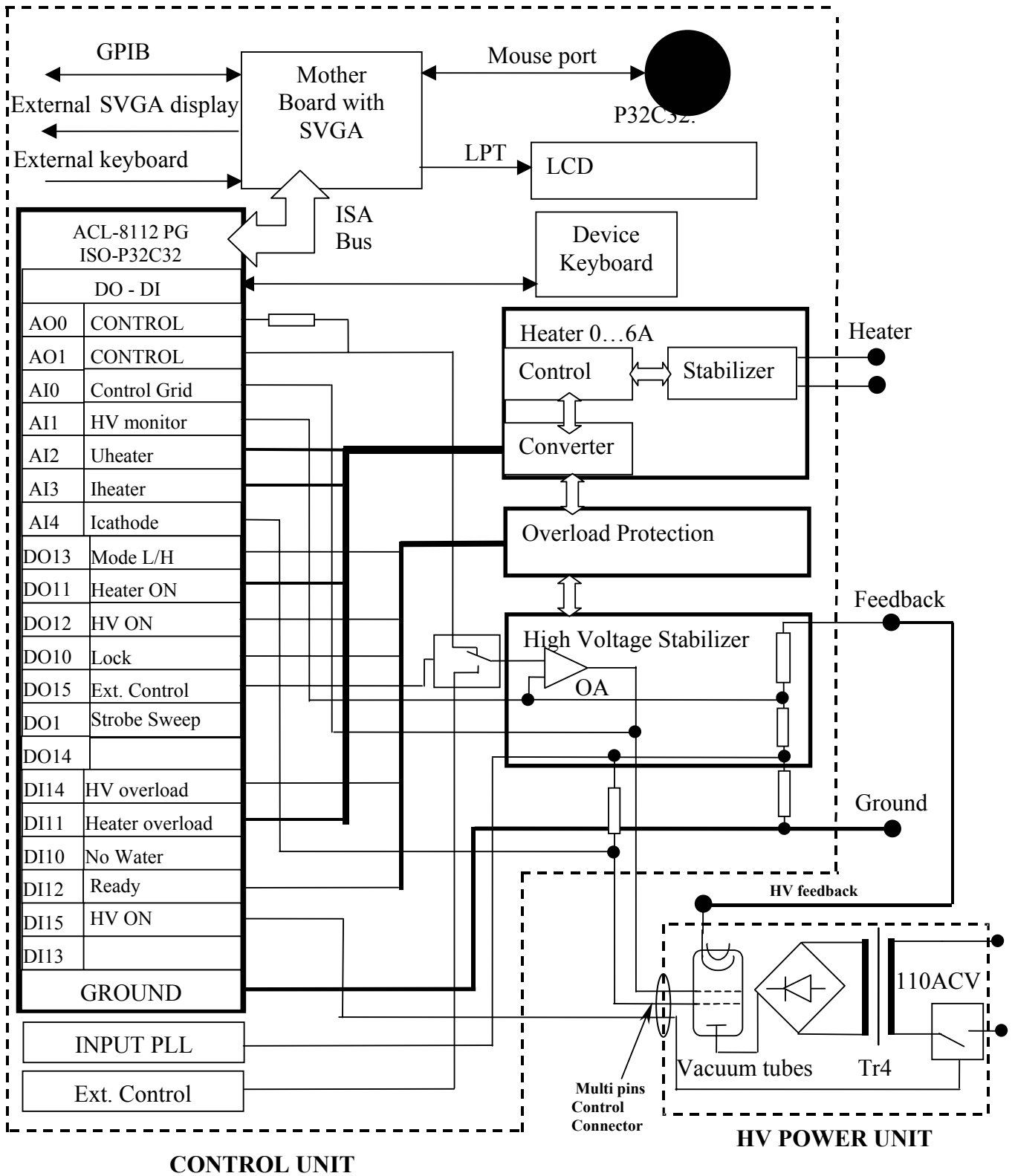

5.6 Figure 6

Scheme of connection PSM with Clinotron.

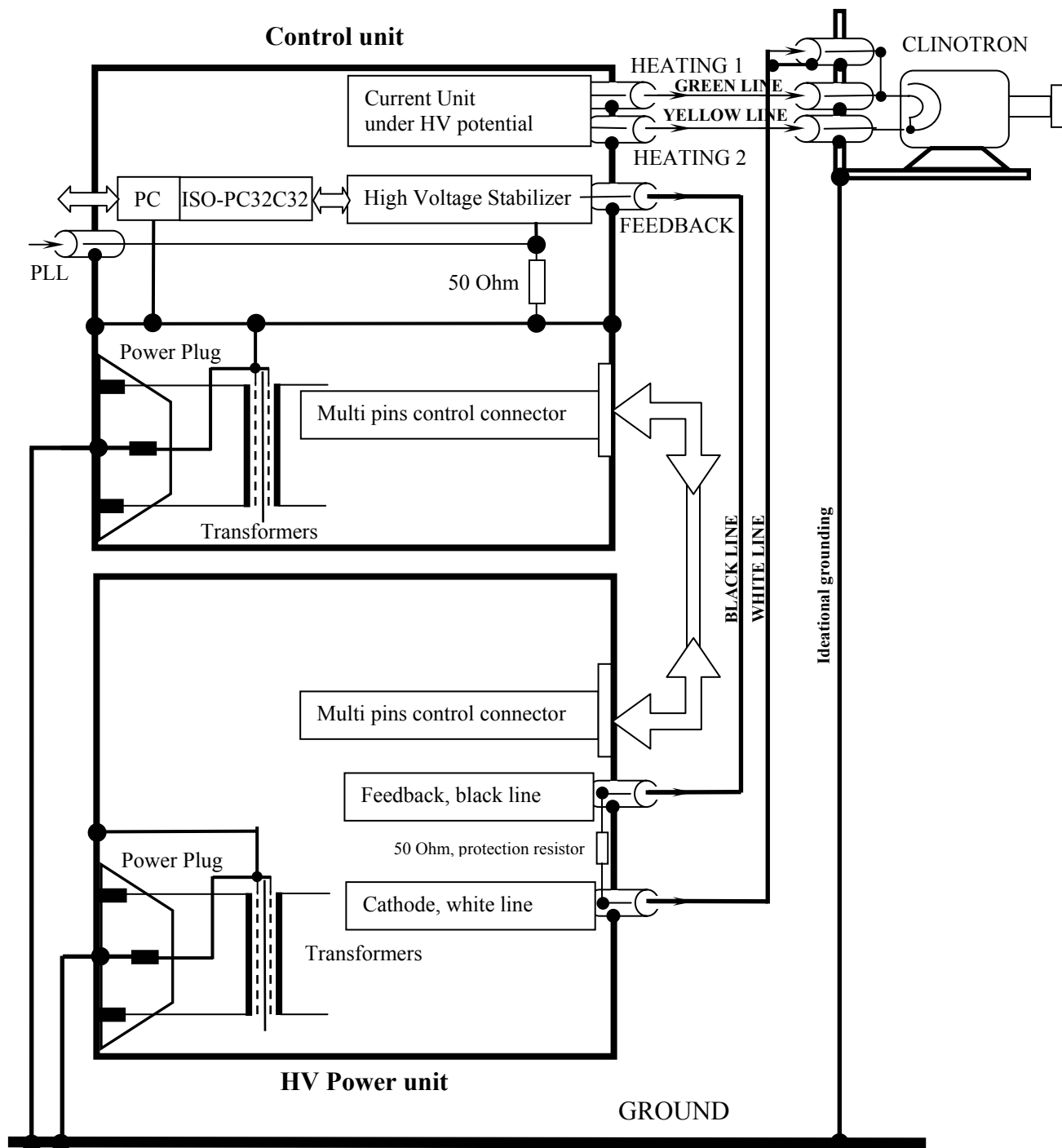

NOTES.

1. For all connections please use cables according to colour marking only.
2. Cables for heater are specially grounded from one end only.
3. Clinotron's circuit is grounded via cathode (white) line only.
4. Recommended for additional safety to use grounding of Clinotron's unit via separated wire.

### 5.7 Figure 7

The diagram of the Output Voltage and strobes.

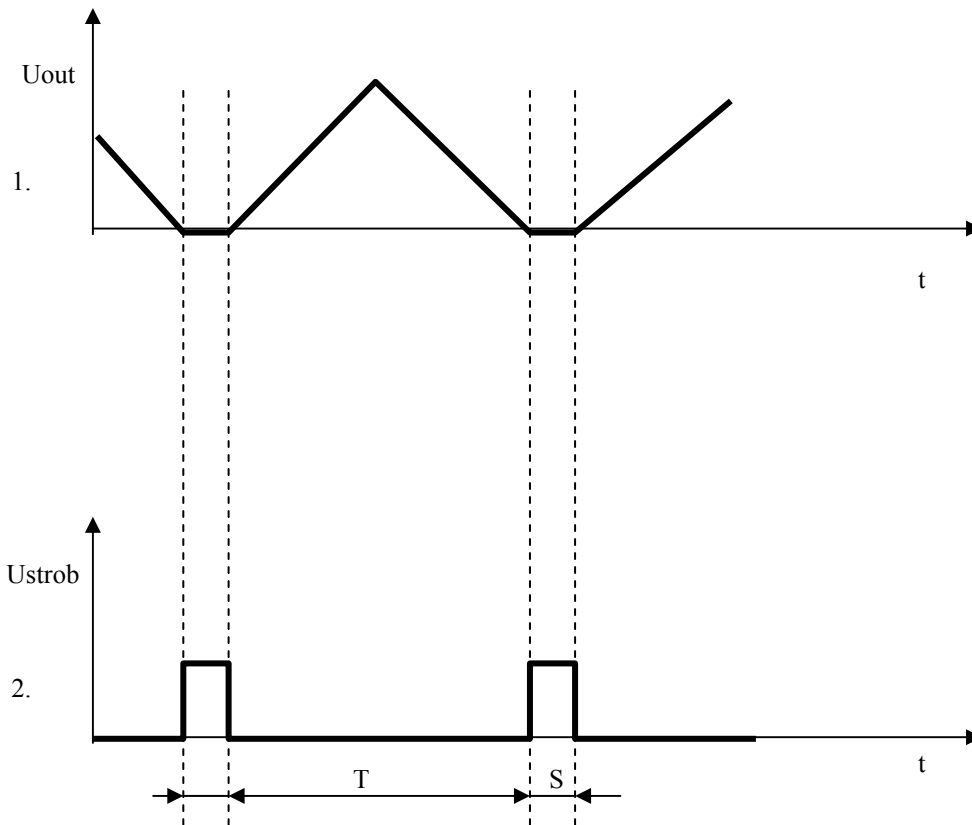

1. The diagram of the Output Voltage.

2. The diagram of TTL output strobe signal on plug (30 ).

T – sweep time, set by Digital Keyboard (15) or by GPIB bus command.

S – strobe time, duration about 0.001 sec.

5.8 Figure 8  
Calibration data.

